

## HEREDITARY HEMOCHROMATOSIS IN ADULTS WITHOUT PATHOGENIC MUTATIONS IN THE HEMOCHROMATOSIS GENE

ANTONELLO PIETRANGELO, M.D., PH.D., GIULIANA MONTOSI, PH.D., ANGELA TOTARO, PH.D., CINZIA GARUTI, PH.D.,  
DARIO CONTE, M.D., STEFANO CASSANELLI, PH.D., MIRELLA FRAQUELLI, M.D., CARLA SARDINI, M.D.,  
FRANCESCO VASTA, M.D., AND PAOLO GASPARINI, M.D.

## ABSTRACT

**Background and Methods** Hereditary hemochromatosis in adults is usually characterized by mutations in the hemochromatosis (*HFE*) gene on the short arm of chromosome 6. Most patients have a substitution of tyrosine for cysteine at position 282 (C282Y). We studied a large family from Italy that includes persons who have a hereditary iron-overload condition indistinguishable from hemochromatosis but without apparent pathogenic mutations in the *HFE* gene. We performed biochemical, histologic, and genetic studies of 53 living members of the family, including microsatellite analysis of chromosome 6 and direct sequencing of the *HFE* gene.

**Results** Of the 53 family members, 15 had abnormal serum ferritin levels, values for transferrin saturation that were higher than 50 percent, or both. Thirteen of the 15 had elevated body iron levels, diagnosed on the basis of the clinical evaluation and liver biopsy, and underwent iron-removal therapy. The other two, both children, did not undergo liver biopsy or iron-removal therapy. None of the 15 members had the C282Y mutation of the *HFE* gene; 5 of the 15 (as well as 5 healthy relatives) had another mutation of this gene, a substitution of aspartate for histidine at position 63, but none were homozygous for it. No other mutations were found after sequencing of the entire *HFE* gene for all family members. Microsatellite analysis showed no linkage of the hemochromatosis phenotype with the short arm of chromosome 6, the site of the *HFE* gene.

**Conclusions** Hereditary hemochromatosis can occur in adults who do not have pathogenic mutations in the hemochromatosis gene. (N Engl J Med 1999; 341:725-32.)

©1999, Massachusetts Medical Society.

THE term "hemochromatosis" was used by von Recklinghausen in 1889 to denote an iron-storage disease with widespread tissue injury.<sup>1</sup> In 1996, a candidate gene for hereditary hemochromatosis (*HFE*) was identified.<sup>2</sup> The majority of patients with hemochromatosis (83 to 100 percent in various series) have a substitution of tyrosine for cysteine at position 282 (C282Y).<sup>2,3</sup> A second mutation, a substitution of aspartate for histidine at position 63 (H63D), is present in a minority of patients, but its role in the pathogenesis of the disease is uncertain.<sup>2,4</sup>

The isolation of the *HFE* gene provided the opportunity to analyze directly the effect of genetic mu-

tations on phenotype. The existence of a highly prevalent mutation supports the concept of a founder effect (i.e., the genetic mutation that causes hemochromatosis was a unique event in a single person), but it is difficult to explain the phenotypic variation on the basis of *HFE* genotypes. Recent studies showed that only 64 percent of patients with hemochromatosis in Italy were homozygous for the C282Y mutation,<sup>5,6</sup> with a similar proportion in other southern European countries.<sup>7</sup> These findings suggest either that other mutations are present in regions of the *HFE* gene not yet analyzed, such as the promoter region, or that the disorder is characterized by genetic heterogeneity, which has been confirmed in the case of juvenile hemochromatosis.<sup>8</sup>

We describe a large family that includes members with a hereditary iron-overload condition with a phenotypic expression that meets the clinical, biochemical, and histopathological criteria for the diagnosis of hereditary hemochromatosis. However, this hereditary condition is not associated with *HFE* mutations or HLA haplotypes and is not linked to the short arm of chromosome 6 (6p).

## METHODS

## Subjects

The study began in 1983 with the evaluation of a patient (the proband) who had a primary iron-overload condition and was undergoing repeated phlebotomy at the University of Modena, in Modena, Italy. Between 1983 and 1998, serum iron (i.e., transferrin saturation and ferritin) was measured in the proband and 52 members of his family. The family tree is shown in Figure 1. The study was approved by the ethics committee at the University of Modena, and all the family members gave written informed consent.

## Iron Studies

Transferrin saturation and serum ferritin were measured by standard methods in samples obtained after an overnight fast from all 53 family members. In selected family members, the hepatic iron concentration was determined with the use of an atomic-absorption spectrophotometer (model S2380, Perkin-Elmer, Norwalk, Conn.), as described elsewhere,<sup>9</sup> and the hepatic iron index (the ratio of the hepatic iron concentration [expressed as

From the Department of Internal Medicine, Università di Modena, Modena (A.P., G.M., C.G., S.C., C.S., F.V.); Ospedale San Giovanni Rotondo, Foggia (A.T., P.G.); and the Department of Gastroenterology, Università di Milano, Milan (D.C., M.F.) — all in Italy. Address reprint requests to Dr. Pietrangelo at the Department of Internal Medicine, Policlinico, Via del Pozzo 71, 41100 Modena, Italy, or at pietra@unimo.it.

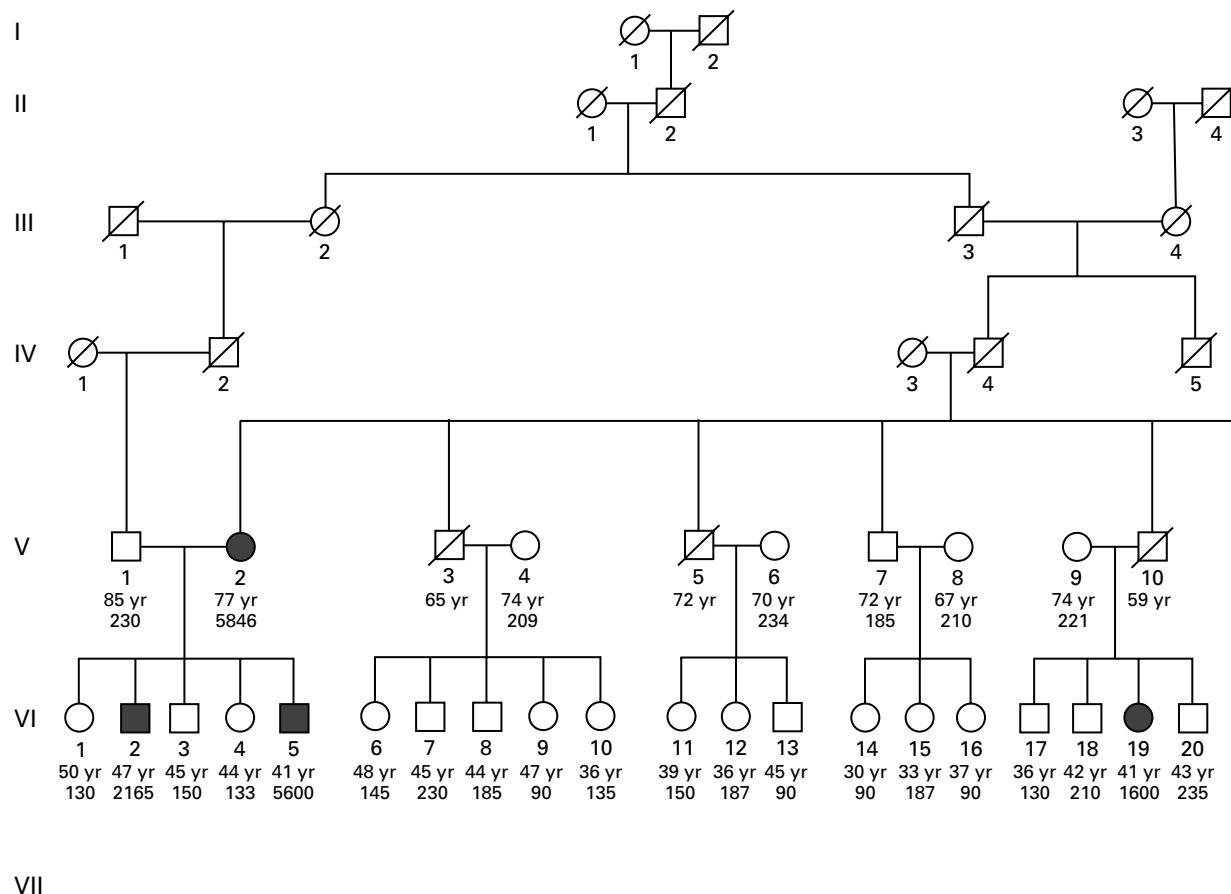

**Figure 1. Pedigree of the Family.**

Circles represent female family members; squares male family members; solid symbols members with abnormal iron values, phenotypically expressed hemochromatosis, or both; and slashes members who had died. The arrow indicates the proband. Below the symbol for each family member are the age in 1998 and the ferritin level, in nanograms per milliliter. The pedigree shows consanguinity between the proband's affected sister (Subject V-2) and her husband (Subject V-1) and high serum ferritin values in members of three consecutive generations of the proband's family.

micromoles per gram of liver, dry weight] to age) was calculated. For members of the family who were treated with phlebotomy, the total amount of iron removed was calculated as the number of phlebotomies (with 400 ml of blood drawn at each session) multiplied by 250 (the number of milligrams of iron removed per session). For the family members who underwent liver biopsy, 5- $\mu$ m sections of liver-biopsy specimens were stained with hematoxylin and eosin and Perls' Prussian blue for the presence of iron and with Sirius red for the presence of collagen.

**Clinical Evaluation**

All family members were questioned about previous blood transfusions, iron-containing medications, and daily consumption of alcohol. Serum samples were obtained for standard tests of hepatitis B virus surface antigen and hepatitis C virus antibodies and RNA. Hemoglobin electrophoresis was performed, and glucose-6-phosphate dehydrogenase and pyruvate kinase were measured.

All family members with clinically expressed hemochromatosis underwent bone marrow aspiration and ultrasonographic measurement of the spleen.

**Molecular Studies**

Haplotype analysis was performed with the use of five microsatellite markers from the *HFE* locus on chromosome 6 (D6S422, D6S265, D6S105, D6S1281, and D6S276).<sup>10</sup> Polymerase-chain-reaction (PCR) assays with fluorescently labeled primers were performed according to standard protocols. The assays were performed in an ABI PRISM DNA sequencer (model 373 or 377, Applied Biosystems, Foster City, Calif.), and the results were processed with Genescan software. Alleles were identified with the use of Genotyper software. HLA antigens were identified with a standard microlymphocytotoxicity test.

Genotypic evaluation was based on the analysis of *HFE* genotypes. The two *HFE* mutations were detected with PCR assays,<sup>2</sup>

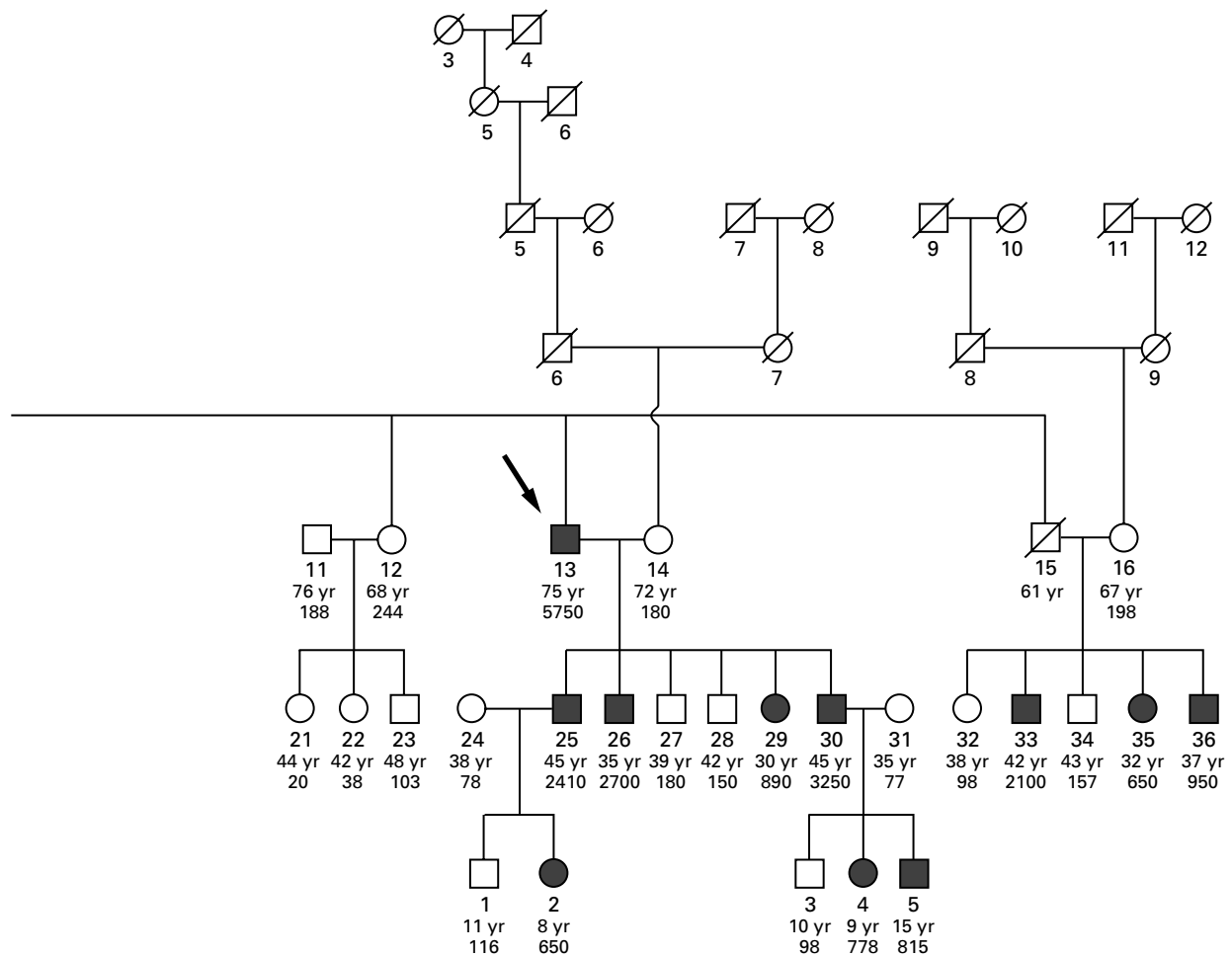

followed by restriction-enzyme digestion with *RsaI* for the C282Y mutation and *BclI* for the H63D mutation.<sup>6</sup> Direct sequencing of *HFE* coding regions (exons plus intron-exon boundaries) was performed as described elsewhere.<sup>5</sup> Briefly, amplified PCR fragments were purified with the use of a purification kit (Boehringer-Mannheim, Indianapolis) and were sequenced with the use of a dye-terminator cycle-sequencing kit (Thermosequenase, version 2.0, Amersham Pharmacia Biotech, Rainham, United Kingdom). The fragments were then electrophoretically separated and analyzed on an ABI PRISM 373 or 377 sequencer.

**RESULTS**

A total of 53 family members (25 males and 28 females) were evaluated. Serum ferritin values were recorded for all subjects (Fig. 1). Fifteen of the subjects had a level of transferrin saturation above 50 percent, an abnormal ferritin level, or both (Table 1). None of the 15 had thalassemia or hemolytic conditions, as indicated by the values for hemoglobin, lactate dehydrogenase, and haptoglobin and the reticulocyte count, and none had ultrasonographic evidence of splenomegaly. Physical examination showed

hyperpigmentation in most of the family members. None had serum antibodies against hepatitis C virus; one member (Subject VI-2) had hepatitis B virus antigen. Bone marrow examination showed normal cellularity, with an absence of sideroblasts, and marked reticuloendothelial-cell iron deposits, particularly in the proband and his offspring. All family members reported that they consumed less than 10 g of alcohol per day.

Thirteen of the 15 subjects with abnormal iron values received a diagnosis of iron overload that was based on a complete clinical evaluation, including liver biopsy, and were enrolled in a phlebotomy program. Two of the 15 were children in the seventh generation of the family (Fig. 1 and Table 1, Subjects VII-2 and VII-4) who had abnormal iron values but did not undergo liver biopsy or iron-removal therapy. Most of the 13 subjects who underwent phlebotomy required a weekly regimen, and in most cases it was well tolerated. In all 13 subjects, serum ferritin and

**TABLE 1.** BIOCHEMICAL AND CLINICAL CHARACTERISTICS OF THE 15 FAMILY MEMBERS WITH ABNORMAL IRON VALUES.\*

SUBJECT	AGE AT DIAGNOSIS	SEX	HEMOGLOBIN†	TRANSFERRIN SATURATION	SERUM FERRITIN	HEPATIC IRON	HEPATIC IRON INDEX‡	TOTAL IRON REMOVED§	H63D MUTATION	LIVER FIBROSIS	ADDITIONAL CLINICAL FINDINGS
	yr		g/dl	%	ng/ml	$\mu\text{mol/g}$ of liver (dry weight)		g			
V-2	61	F	14.5	89	5846	310	5.1	12	-/-	Yes	Arrhythmia, impaired glucose tolerance
V-13 (proband)	59	M	16.0	75	5750	646	10.9	35	-/-	Yes (minimal)	
VI-2	35	M	13.8	78	2165	518	14.8	14	+/-	Yes	Arthritis
VI-5	30	M	14.3	88	5600	815	27.2	16	+/-	Yes	Impotence
VI-19	35	F	13.7	35	1600	155	4.4	5	-/-	No	
VI-25	34	M	15.7	60	2410	810	23.8	31	-/-	No	
VI-26	20	M	15.0	40	2700	220	11.0	12	+/-	No	
VI-29	21	F	14.2	30	890	110	5.2	6	+/-	No	
VI-30	37	M	15.0	65	3250	1050	28.4	20	-/-	No	
VI-33	39	M	15.5	78	2100	655	16.8	8	-/-	No	
VI-35	29	F	14.1	30	650	110	3.8	4	-/-	No	
VI-36	34	M	15.7	80	950	456	13.4	6	-/-	No	
VII-2	7	F	12.5	24	650	ND	ND	ND	-/-	ND	
VII-4	8	F	13.1	20	778	ND	ND	ND	-/-	ND	
VII-5	14	M	13.8	28	815	75	5.4	4	+/-	No	

\*ND denotes not determined. Plus signs indicate the presence of the mutation, and minus signs its absence.

†To convert the values for hemoglobin to millimoles per liter, multiply by 0.6206.

‡The hepatic iron index is the ratio of the hepatic iron concentration to the patient's age at the time of the evaluation.

§The total amount of iron removed was calculated as the number of phlebotomies (with 400 ml of blood drawn per session) multiplied by 250 (the number of milligrams of iron removed per session).

transferrin saturation returned to normal levels, which were subsequently maintained with a less intensive regimen of phlebotomy. The total amount of iron removed during the intensive regimen ranged from 4 to 35 g (Table 1). In two of the proband's children (Subjects VI-26 and VI-30), the weekly phlebotomy regimen resulted in slight anemia and low transferrin saturation while the serum ferritin level remained elevated. A less aggressive regimen also resulted in iron depletion. The clinical manifestations of iron overload were most severe in two family members: the proband's sister (Subject V-2), who had arrhythmia and impaired glucose tolerance, and one of her sons (Subject VI-5), who had impotence that was not reversed by phlebotomy.

Liver biopsy in the proband, who was 59 years old when the liver disease was diagnosed, showed a dramatic accumulation of iron (Fig. 2B). In liver specimens from the proband and from five members of his family (Subjects VI-25, VI-26, VI-29, VI-30, and VII-5), the pattern of iron overload was mixed, involving both parenchymal cells (with a decreasing gradient throughout lobules) and mesenchymal cells, with large, coalescent iron deposits in Kupffer cells and portal macrophages (Fig. 2B and 2D). Kupffer-cell iron load was an early event in all six subjects

(Fig. 2D). Marked iron deposition was also seen within vascular walls, with the pericanalicular pattern in parenchymal cells that is characteristic of classic hereditary hemochromatosis. There was minimal portal fibrosis in the specimen from the proband, with no fibrosis or only slight sinusoidal fibrosis in the specimens from his five relatives. No necrotic or inflammatory changes were seen, and there was minimal macrovesicular steatosis. The pathological findings were most severe in the specimens from the proband's sister and her two affected sons, which showed fibrotic changes (Fig. 2A and 2C) and a pattern of iron distribution that is characteristic of hemochromatosis: parenchymal iron overload, with periportal accumulation of iron and minimal deposits in reticulo-endothelial cells.

None of the 15 family members with abnormal iron values had the C282Y mutation of the *HFE* gene; 5 of the 15 (Table 1) and 5 members with normal iron values had the H63D mutation, but none were homozygous. No other mutations were found after sequencing of the whole *HFE* gene for all family members. Haplotypes were also analyzed for all the family members with the use of five microsatellites specific to the *HFE* locus on chromosome 6. With a recessive pattern of inheritance, the haplotype should

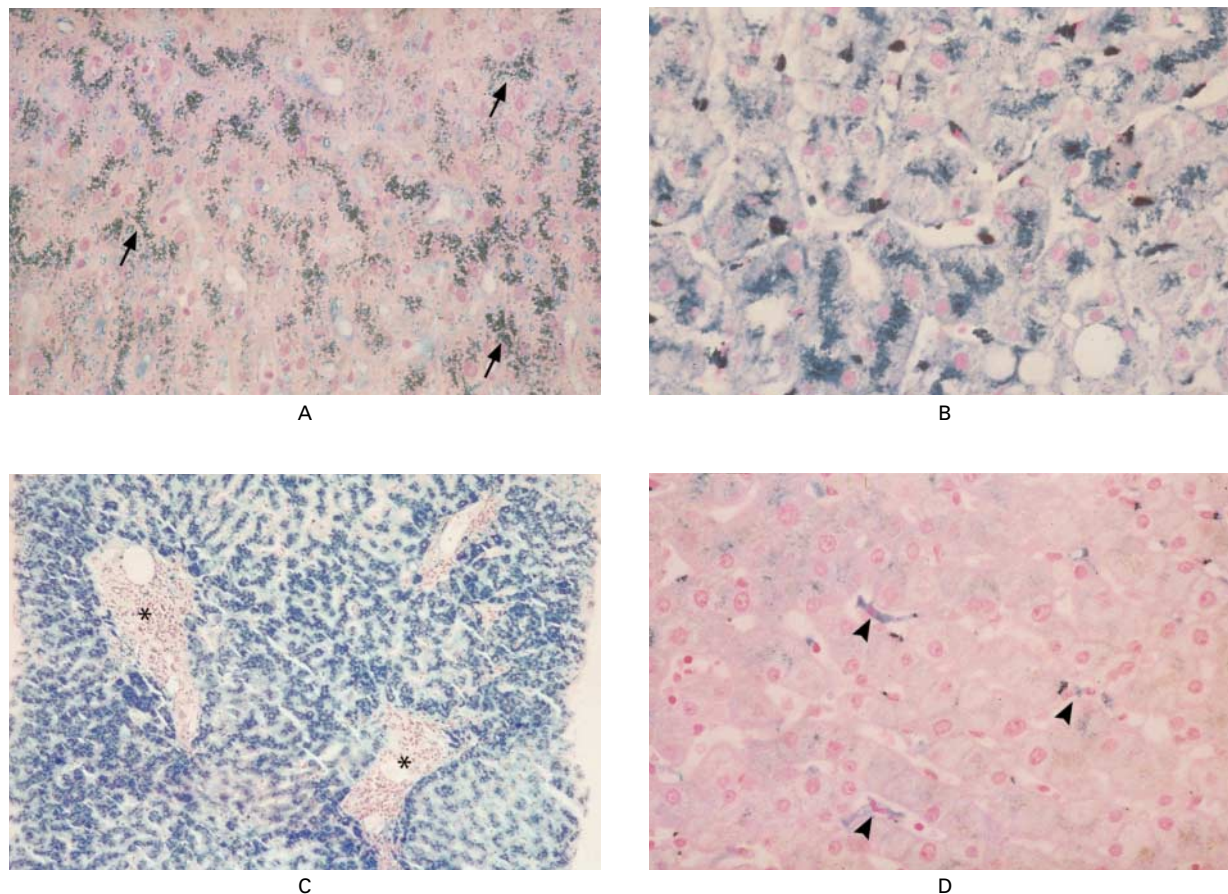

**Figure 2.** Liver-Biopsy Specimens from Four Members of the Family.

Perls' Prussian blue stain was used to detect the presence of iron. Panel A ( $\times 533$ ) shows the specimen from the proband's affected sister (Subject V-2), with an iron concentration of  $310 \mu\text{mol}$  per gram of liver, dry weight; Panel B ( $\times 533$ ) shows the specimen from the proband (Subject V-13), with an iron concentration of  $646 \mu\text{mol}$  per gram; Panel C ( $\times 133$ ) shows the specimen from the proband's affected sister (Subject VI-5), with an iron concentration of  $815 \mu\text{mol}$  per gram; and Panel D ( $\times 533$ ) shows the specimen from the proband's affected daughter (Subject VI-29), with an iron concentration of  $110 \mu\text{mol}$  per gram. The specimens from the proband's sister and her son show the pattern of iron distribution that is characteristic of hemochromatosis: iron is accumulated almost exclusively within the parenchymal cells, with a granular pattern and a pericanalicular distribution (Panel A, arrows) and with initial fibrosis (Panel C, asterisks). The specimens from the proband and his daughter show a mixed pattern of iron overload: in addition to the iron deposits in parenchymal cells (Panel B), there are prominent deposits in sinusoidal cells, even at the early stage of the disease, in the daughter, who was 21 years old at the time of the biopsy (Panel D, arrowheads).

be associated with the phenotype in all affected members. As Figure 3 shows, there was no association between haplotype and phenotype in the family we studied. Affected family members had different haplotypes (e.g., Subject VI-2 had haplotype  $A_2/B_2$ , and Subject VI-5 had haplotype  $A_2/B_1$ ), and in several cases, healthy members had the same haplotypes as affected members (e.g., Subjects VI-3 and VI-5 both had haplotype  $A_2/B_1$ ). With a dominant pattern of inheritance, the same haplotype should be present in all affected members and absent in all healthy members, except in the case of an absence of penetrance. Again, there were no *HFE* haplotypes that seg-

regated with the phenotype in this family. Similarly, analysis of HLA haplotypes showed that the markers associated with hereditary hemochromatosis were absent (data not shown).<sup>6,11</sup>

#### DISCUSSION

We studied a large family in which several members had an iron-overload condition that met most of the accepted diagnostic criteria for hereditary hemochromatosis. The most common forms of secondary iron overload were ruled out in these patients. The iron-overload disease in this family was not due to the presence of the C282Y mutation of the *HFE*

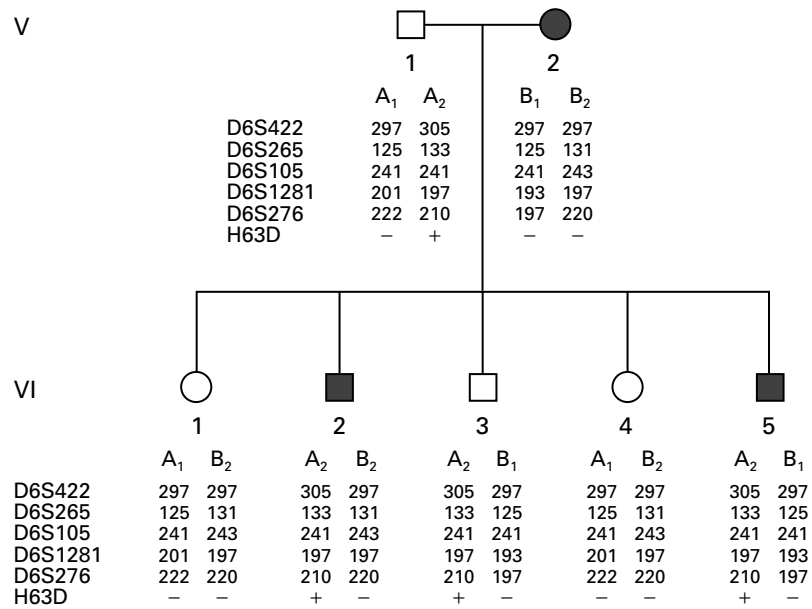

**Figure 3.** Haplotype Analysis of Chromosome 6 in Selected Family Members.

Circles represent female family members, squares male family members, and solid symbols members with hemochromatosis. Five microsatellite markers (D6S422, D6S265, D6S105, D6S1281, and D6S276) spanning the short arm of chromosome 6, where the *HFE* gene lies, were analyzed. Each of these markers comes in two allelic forms (i.e., a form for each homologous chromosome) identified by numbers (e.g., 297 and 305 for the D6S422 marker in Subject V-1). The five allelic variants of each chromosome (the column of numbers) constitute a specific haplotype. The haplotypes are identified by the letters above the columns: A<sub>1</sub>, A<sub>2</sub>, B<sub>1</sub>, B<sub>2</sub>, C<sub>1</sub>, C<sub>2</sub>, D<sub>1</sub>, D<sub>2</sub>, and D<sub>R</sub> (D<sub>R</sub> indicates a recombinant event). Each person receives one haplotype from the father and one from the mother. The H63D genotype of the *HFE* gene is shown below the haplotypes (the plus sign indicates the presence of the mutation, and the minus sign its absence). The microsatellite data indicate that hemochromatosis in this family was not linked to chromosome 6p. In addition, the H63D mutation of the *HFE* gene does not appear to be linked to the disease, since some affected family members did not have the mutation (e.g., Subject V-2), some affected members were heterozygous for the mutation (e.g., Subject VI-5), and some healthy members were heterozygous for the mutation (e.g., Subject VI-3).

gene. In addition, the H63D mutation did not seem to have a role in the disease, since family members with the mutation had varying degrees of iron overload, and some affected family members, as well as healthy members, did not have the mutation. Our genetic study also ruled out the possibility of other mutations in the coding regions or the intron-exon boundaries of the *HFE* gene. However, additional mutations may be present in regions of the *HFE* gene that have not yet been characterized, such as the recently described promoter region at the 5' end of the *HFE* gene.<sup>12</sup> However, since in this family hemochromatosis did not segregate with specific haplotypes of the short arm of chromosome 6, where the *HFE* gene lies, the involved gene (or genes) is not associated with 6p where enhancer-promoter regions of the *HFE* gene are likely to reside.

Among the subjects with iron overload, there were two patterns of presentation. The proband (Subject V-13), four of his children (Subjects VI-25, VI-26,

VI-29, and VI-30), and one of his grandchildren (Subject VII-5) had nonclassic hemochromatosis, characterized by a mixed pattern of iron accumulation in the liver and minimal fibrosis. In addition, Subjects VI-29, VII-2, VII-4, and VII-5 had an increase in serum ferritin levels in the presence of low-to-normal transferrin saturation (Table 1), with an early decrease in serum iron values and hemoglobin levels despite persistently high ferritin levels in those who underwent phlebotomy, and Subjects VI-26 and VI-30 had a low tolerance of the phlebotomy regimen. Although some of these features may suggest the presence of a hematologic, possibly hemolytic disorder, none of the family members with iron overload were anemic, and none of the analyses we performed suggested the presence of an underlying hemolytic condition. The proband's affected sister (Subject V-2) and her two affected children (Subjects VI-2 and VI-5) had a type of hereditary hemochromatosis that was identical to the *HFE*-associated

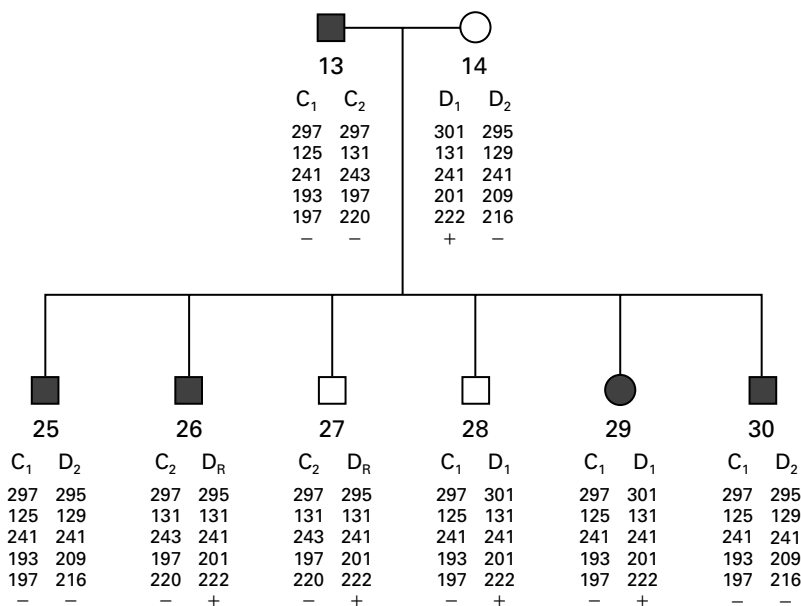

type in its biochemical, pathological, and clinical expression, with endocrine and cardiac involvement.

At least two other hereditary conditions associated with iron overload have been described: siderosis in sub-Saharan Africa, which results from the interaction between an HLA-independent genetic component and environmental factors,<sup>13,14</sup> and the rare juvenile form of hemochromatosis.<sup>15</sup> Neither condition is linked to the short arm of chromosome 6, and the causative genes have not yet been identified or mapped to specific chromosomes. African siderosis may share some features of the hemochromatotic condition in the proband and his offspring, with extensive iron deposits in reticuloendothelial cells, as well as parenchymal iron overload in periportal areas. Juvenile hemochromatosis is a severe form of iron overload that develops in the second or third decade of life, with a prevalence of cardiac and endocrine involvement. This condition has been reported mainly in southern Italy, and the family described here originates from the same area. A recent report described two related patients with clinical findings suggestive of an atypical form of juvenile hemochromatosis; neither patient had the C282Y mutation or the H63D mutation, although other *HFE* mutations and a link to 6p could not be ruled out.<sup>16</sup> Whether the classic form of hemochromatosis in the family described here, especially in the proband's sister and two of her children, represents a mild, late form of juvenile hemochromatosis remains to be determined.

In conclusion, our study indicates the existence of one or more distinct genetic diseases that cause a type of adult hereditary iron overload other than that

associated with the *HFE* gene. The clinical entity resembles *HFE*-associated hemochromatosis. Our data suggest that it arises from anomalies in at least two genes. We speculate that homozygosity for a defect in a gene other than *HFE* may be responsible for the classic form of hemochromatosis in some members of the family we studied, whereas a defect in a second gene, apparently transmitted in a dominant fashion throughout three generations of the family, may account for the nonclassic form of the disorder in other members. The variable clinical and histopathological phenotype in the family may reflect compound heterozygosity or homozygosity for these two genes.

Supported by a grant from Azienda Ospedaliera Policlinico di Modena and by a grant (E-609) from Telethon-Italy to Dr. Pietrangelo.

## REFERENCES

1. von Recklinghausen FD. *Über Haemochromatose*: Taggeblatt der (62). Heidelberg, Germany: Versammlung deutscher Naturforscher und Aerzte, 1889:324-5.
2. Feder JN, Gnirke A, Thomas W, et al. A novel MHC class I-like gene is mutated in patients with hereditary haemochromatosis. *Nat Genet* 1996; 13:399-408.
3. Hemochromatosis and *HLA-H*. *Nat Genet* 1996;14:249-52.
4. Beutler E. The significance of the 187G (H63D) mutation in hemochromatosis. *Am J Hum Genet* 1997;61:762-4.
5. Carella M, Dambrosio L, Totaro A, et al. Mutation analysis of the HLA-H gene in Italian hemochromatosis patients. *Am J Hum Genet* 1997; 60:828-32.
6. Piperno A, Sampietro M, Pietrangelo A, et al. Heterogeneity of hemochromatosis in Italy. *Gastroenterology* 1998;114:996-1002.
7. Borot N, Roth M, Malfroy L, et al. Mutations in the MHC class I-like candidate gene for hemochromatosis in French patients. *Immunogenetics* 1997;45:320-4.
8. Camaschella C, Roetto A, Cicilano M, et al. Juvenile and adult hemochromatosis are distinct genetic disorders. *Eur J Hum Genet* 1997;5:371-5.

9. Rocchi E, Gilbertini P, Cassanelli M, Pietrangelo A, Ventura E. Serum ferritin in the assessment of liver iron overload and iron removal therapy in porphyria cutanea tarda. *J Lab Clin Med* 1986;107:36-42.
10. Dib C, Faure S, Fizames C, et al. A comprehensive genetic map of the human genome based on 5,264 microsatellites. *Nature* 1996;380:152-4.
11. Simon M, Bourel M, Fauchet R, Genetet B. Association of HLA-A3 and HLA-B14 antigens with idiopathic haemochromatosis. *Gut* 1976;17:332-4.
12. Sanchez M, Queralt R, Bruguera M, Rodes J, Oliva R. Cloning, sequencing and characterization of the rat hereditary hemochromatosis promoter: comparison of the human, mouse, and rat *HFE* promoter regions. *Gene* 1998;225:77-87.
13. Gordeuk V, Mukiibi J, Hasstedt SJ, et al. Iron overload in Africa: interaction between a gene and dietary iron content. *N Engl J Med* 1992;326:95-100.
14. McNamara L, MacPhail AP, Gordeuk VR, Hasstedt SJ, Rouault T. Is there a link between African iron overload and the described mutations of the hereditary haemochromatosis gene? *Br J Haematol* 1998;102:1176-8.
15. Perkins KW, McInnes IWS, Blackburn CRB, Beal RW. Idiopathic hemochromatosis in children: report of a family. *Am J Med* 1965;39:118-26.
16. Camaschella C, Fargion S, Sampietro M, et al. Inherited HFE-unrelated hemochromatosis in Italian families. *Hepatology* 1999;29:1563-4.