

REVIEW ARTICLE

GENOMIC MEDICINE

Alan E. Guttmacher, M.D., and Francis S. Collins, M.D., Ph.D., *Editors*

## Hereditary Colorectal Cancer

Henry T. Lynch, M.D., and Albert de la Chapelle, M.D., Ph.D.

**T**HE ANNUAL INCIDENCE OF COLORECTAL CANCER IN THE UNITED States is approximately 148,300 (affecting 72,600 males and 75,700 females), with 56,600 deaths (in 27,800 males and 28,800 females).<sup>1</sup> The lifetime risk of colorectal cancer in the general population is about 5 to 6 percent.<sup>1</sup> Patients with a familial risk — those who have two or more first- or second-degree relatives (or both) with colorectal cancer — make up approximately 20 percent of all patients with colorectal cancer, whereas approximately 5 to 10 percent of the total annual burden of colorectal cancer is mendelian in nature — that is, it is inherited in an autosomal dominant manner. In this review we will focus on the two major forms of hereditary colorectal cancer, familial adenomatous polyposis and hereditary nonpolyposis colorectal cancer.

From the Department of Preventive Medicine and Public Health, Creighton University School of Medicine, Omaha, Nebr. (H.T.L.); and the Human Cancer Genetics Program, Comprehensive Cancer Center, Ohio State University, Columbus (A.C.). Address reprint requests to Dr. Lynch at the Department of Preventive Medicine and Public Health, Creighton University School of Medicine, 2500 California Plaza, Omaha, NE 68178, or at [htlynch@creighton.edu](mailto:htlynch@creighton.edu).

N Engl J Med 2003;348:919-32.

Copyright © 2003 Massachusetts Medical Society.

### OVERALL CLINICAL APPROACH

The most important step leading to the diagnosis of a hereditary cancer syndrome is the compilation of a thorough family history of cancer.<sup>2-4</sup> A patient and his or her key relatives, working either alone or with a trained nurse or genetic counselor, can compile such a detailed family history. The focus should be on identifying cancer of all types and sites; the family member's age at the onset of cancer; any pattern of multiple primary cancers; any association with phenotypic features that may be related to cancer, such as colonic adenomas; and documentation of pathological findings whenever possible. This information will frequently identify a hereditary colorectal cancer syndrome in the family, should it exist. Molecular genetic testing may then provide verification of the diagnosis, when a germ-line mutation is present in the family.<sup>5,6</sup> The primary care physician may wish to refer the patient to a hereditary-cancer specialist and genetic counselor for further evaluation should there be any remaining question about the disorder's clinical or molecular genetic diagnosis and the need for targeted surveillance and management.

Once a diagnosis of a hereditary colorectal cancer syndrome is established, the proband's high-risk relatives should be notified, and genetic counseling and DNA testing should be performed in consenting relatives, when such testing is appropriate. In an attempt to reduce morbidity and mortality, surveillance measures may then be instituted that reflect the natural history of the disorder.<sup>7</sup>

Once it is clear that a patient has a familial form of colorectal cancer, genetic counseling is mandatory and must provide the patient and his or her extended family with important details about their genetic risk of cancer at specific sites, on the basis of the natural history of the hereditary cancer syndrome; the options for surveillance and management; and the availability of genetic testing.<sup>8,9</sup> Counseling should be face to face, but a session may include multiple family members.<sup>8</sup> The concept of informed consent implies that a patient has received counseling, information, and putative test results and

has signed a document to that effect. The results of tests for mutations should be revealed to the patient on a one-to-one basis.<sup>7</sup>

---

#### DIAGNOSTIC CLUES

---

Syndromes with distinguishing phenotypes, such as florid colonic adenomas in familial adenomatous polyposis, are easier to diagnose than hereditary disorders that lack clear phenotypic characteristics. For instance, the attenuated polyposis phenotype of familial adenomatous polyposis is characterized by a paucity of colonic adenomas, and the ones that do occur are primarily in the proximal colon. The onset of colorectal cancer is at a later average age (approximately 55 years) than that of classic familial adenomatous polyposis (approximately 39 years). These differences make it more difficult for clinicians to diagnose than its classic counterpart, despite their having a high index of suspicion for a familial colorectal cancer syndrome.<sup>10,11</sup>

In the case of hereditary nonpolyposis colorectal cancer, five cardinal features will help to identify affected families. The first is an earlier average age at the onset of cancer than in the general population; for example, the average age at the onset of hereditary nonpolyposis colorectal cancer is approximately 45 years,<sup>7</sup> whereas the average age at the onset of sporadic cases is approximately 63 years. The second feature is a particular pattern of primary cancers segregating within the pedigree, such as colonic and endometrial cancer.<sup>7,12</sup> The third is survival that differs from the norm for the specific cancer.<sup>13-16</sup> The fourth is distinguishing pathological features,<sup>17,18</sup> and the fifth and sine qua non is the identification of a germ-line mutation in affected members of the family.<sup>5</sup>

There are two broad classes of hereditary colorectal cancer, based on the predominant location of the cancer: distal and proximal. Colorectal cancers involving the distal colon are more likely to have aneuploid DNA, harbor mutations in the adenomatous polyposis coli (APC), p53, and K-ras genes, and behave more aggressively<sup>7</sup>; proximal colorectal cancers are more likely to have diploid DNA, possess microsatellite instability, harbor mutations in the mismatch-repair genes, and behave less aggressively, as in hereditary nonpolyposis colorectal cancer.<sup>7</sup> Familial adenomatous polyposis and most sporadic cases may be considered a paradigm for the first, or distal, class of colorectal cancers, whereas hereditary nonpolyposis colorectal cancer more clearly represents the second, or proximal, class.<sup>7</sup>

A hallmark of tumors in hereditary nonpolyposis colorectal cancer is microsatellite instability.<sup>19-21</sup> Microsatellites are genomic regions in which short DNA sequences or a single nucleotide is repeated. There are hundreds of thousands of microsatellites in the human genome. During DNA replication, mutations occur in some microsatellites owing to the misalignment of their repetitive subunits and result in contraction or elongation ("instability"). These abnormalities are usually repaired by the mismatch-repair proteins. However, repair is inefficient in tumors with a deficiency of these proteins. Typically, in such tumor cells, half or more of all microsatellites have mutations (contraction or elongation), so microsatellite instability serves as an excellent, easy-to-evaluate marker of mismatch-repair deficiency (Fig. 1). Since microsatellite instability is found in virtually all hereditary nonpolyposis colorectal cancers,<sup>29</sup> we consider it unnecessary to search for germ-line mutations in mismatch-repair genes (e.g., MSH2 and MLH1) in patients whose tumors do not have microsatellite instability. An exception is found in families with the MSH6 mutation, in which microsatellite instability may or may not be present.<sup>30,31</sup> Most microsatellites occur in noncoding DNA; therefore, contractions or elongations are believed to have little or no effect on protein function. However, there are genes that have microsatellites in their coding regions (Fig. 2), and microsatellite instability will thus lead to altered proteins.

---

#### FAMILIAL ADENOMATOUS POLYPOSIS

---

##### CLINICAL AND MOLECULAR FEATURES

Multiple colonic adenomas occur at an early age in patients with familial adenomatous polyposis, occasionally during the preteen years, and proliferate throughout the colon, with malignant degeneration in most patients by the age of 40 to 50 years. Patients who have an APC mutation or who have one or more first-degree relatives with familial adenomatous polyposis or an identified APC mutation (or both) are at high risk and should be screened with flexible sigmoidoscopy by the age of 10 to 12 years. Patients with colonic polyps, a verified APC germ-line mutation, or both will require annual endoscopic examination. However, as the disease advances, as is often the case in the late teens and early 20s, too many colonic polyps may be present for adequate and safe colonoscopic polypectomy; when this occurs, prophylactic subtotal colectomy followed by annual endoscopy of the remaining rectum is recommended.

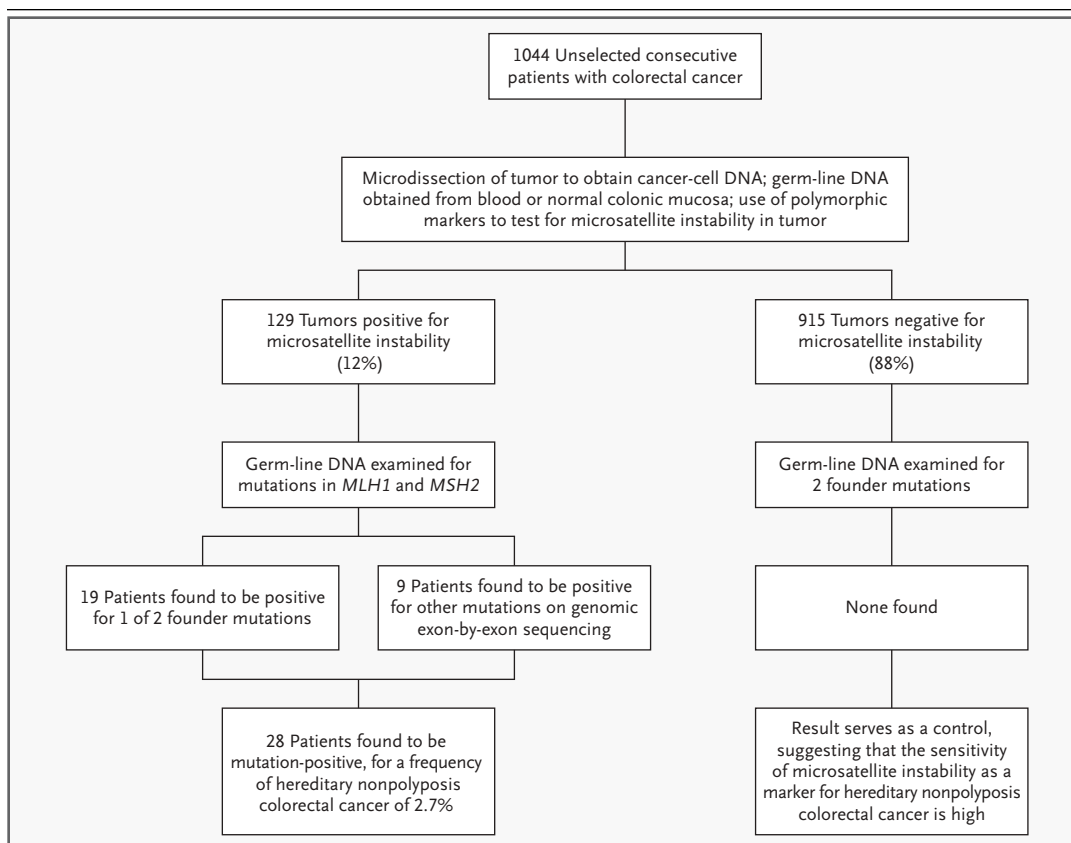
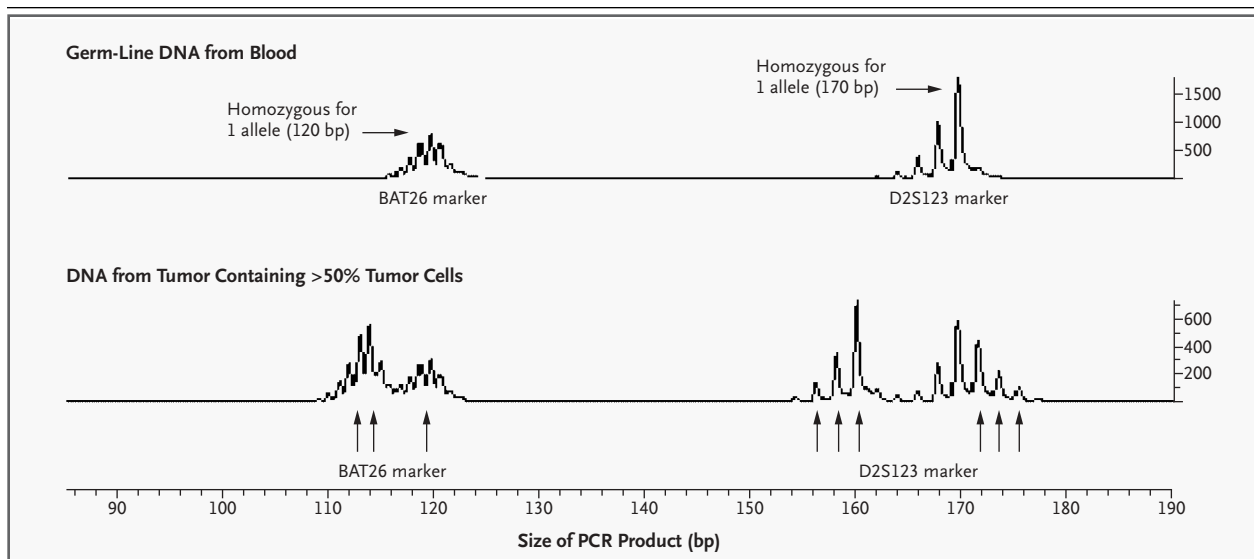

**Figure 1. Approach to Molecular Screening for Hereditary Nonpolyposis Colorectal Cancer in an Unselected Cohort of Consecutive Patients with Newly Diagnosed Colorectal Cancer.**

Data are from Aaltonen et al.<sup>22</sup> and Salovaara et al.<sup>23</sup> This screening strategy relies on microsatellite instability as a primary marker for hereditary nonpolyposis colorectal cancer.<sup>19,24</sup> In most studies of unselected patients with colorectal cancers, the proportion who are positive for microsatellite instability ranges from 12 to 16 percent.<sup>25</sup> For this purpose, microsatellite instability can be determined with the use of just one or two markers and, in many cases, without the need for matching normal DNA.<sup>26,27</sup> Fixed, paraffin-embedded tumor specimens are a readily available source of DNA for this test, but the specimen must be determined histologically to contain at least 30 to 50 percent tumor cells. As a source of germ-line DNA for the detection of mutations, a blood sample is most suitable. The proportion of all patients with colorectal cancer who have hereditary nonpolyposis colorectal cancer may vary among populations. The proportion found in these studies (2.7 percent) is an underestimate, because neither microsatellite-instability testing nor mutation detection is error-free, and mutations were sought only in the *MLH1* and *MSH2* genes. Two founder mutations account for over half of all hereditary nonpolyposis colorectal cancer mutations in this population.<sup>28</sup> These mutations can be easily screened for in large numbers of samples.

Upper endoscopy is also necessary because of the potential for adenomas, which increase the risk of cancer of the stomach. Although cancers of the stomach are uncommon in whites, they are of particular concern to families with familial adenomatous polyposis in Korea and Japan.<sup>32</sup> Adenomas in the duodenum, which carry a risk of a periampullary carcinoma, and in the remainder of the small intestine are more common.<sup>33</sup> There is limited knowledge about the causation, prevention, and manage-

ment of duodenal polyposis in familial adenomatous polyposis. However, there is a strong association with stage IV periampullary adenomas, which pose a high lifetime risk of periampullary carcinoma in patients with familial adenomatous polyposis.<sup>34</sup> Even though the efficacy of screening is yet to be fully demonstrated, Burke<sup>33</sup> recommends upper endoscopic screening with forward- and side-viewing endoscopes for all those with a family history of familial adenomatous polyposis.



**Figure 2.** Detection of Microsatellite Instability with the Use of Fluorescent Labeling of Polymerase-Chain-Reaction (PCR) Products Analyzed in an Automatic Sequencer.

Two markers are analyzed in the same track: the mononucleotide repeat marker BAT26 is shown on the left, and the dinucleotide marker D2S123 is shown on the right. The upper tracing is from germ-line DNA from blood. The lower tracing is from DNA extracted from a histologic section of a tumor containing more than 50 percent tumor cells. For marker BAT26, germ-line DNA shows a single peak, indicating that the patient is homozygous for this marker (arrow). Tumor DNA shows, in addition to the normal allele (single arrow), a new allele (double arrows) that has lost approximately five nucleotides. This constitutes microsatellite instability. For marker D2S123, germ-line DNA is homozygous, whereas tumor DNA shows two new alleles (triple arrows), one with a loss of approximately 10 nucleotides (left) and one with a gain of 2 nucleotides (right). Thus, the tumor shows microsatellite instability with both markers. All peaks display “stutter” — that is, small amounts of material with a gain or a loss of one or a few nucleotides. This is a normal phenomenon.

Desmoids also appear frequently in patients with familial adenomatous polyposis and are often induced by surgery.<sup>35,36</sup> Ideally, prophylactic colectomy should be delayed unless there are too many colonic adenomas to manage safely. Elective surgical procedures should be avoided whenever this is possible. Other, less common tumors that may occur in families with familial adenomatous polyposis include papillary thyroid carcinoma, sarcomas, hepatoblastomas, pancreatic carcinomas, and medulloblastomas of the cerebellar–pontine angle of the brain.<sup>36–41</sup> With the exception of papillary thyroid carcinoma, screening for these tumors is difficult and therefore not generally performed.

The penetrance of germ-line mutations that increase the risk of colorectal cancer varies.<sup>38,40,42</sup> It is 10 to 20 percent for the I1307K APC polymorphism, which occurs predominantly in Ashkenazi Jews (Fig. 3). In contrast, penetrance approaches 100 percent in classic familial adenomatous polyposis,<sup>47</sup> caused by truncating germ-line mutations of the APC gene.

#### GENETIC TESTING

Genetic counseling should be performed by a genetic counselor or medical geneticist before DNA is collected and at the time of the disclosure of test results. We recommend discussing the matter in depth with the parents of patients who are younger than 18 years, as well as with the patients themselves, since polyps may occur in the preteen and teen years, and cancer may occur relatively early in some of these patients. It is important for the counselor to know whether the APC mutation is present, and if so, its probable penetrance, particularly in patients with attenuated familial adenomatous polyposis.<sup>10,37</sup>

#### CHEMOPREVENTION

Patients with familial adenomatous polyposis who were treated with 400 mg of celecoxib, a selective inhibitor of cyclooxygenase-2, twice a day for six months had a 28.0 percent reduction in the mean number of colorectal polyps ( $P=0.003$ ), as compared with patients in the placebo group.<sup>48</sup> How-

Somatic mutations in carriers of I1307K		+A			+G	G to T				-G		
	DNA sequence	GCA	GAA	ATA	AAA	GAA	AAG	ATT	GGA	ACT	AGG	TCA
	Amino acid	Ala	Glu	Ile	Lys	Glu	Lys	Ile	Gly	Thr	Arg	Ser
	Codon no.	1305	1306	1307	1308	1309	1310	1311	1312	1313	1314	1315

**Figure 3. The I1307K Germ-Line Mutation (Polymorphism) of the Adenomatous Polyposis Coli (APC) Gene.**

Shown here is the DNA sequence of codons 1305 through 1315 of the APC gene. Below each codon is the encoded amino acid and the number of the codon. The germ-line mutation of codon 1307 shown in the blue box is a change from T to A that changes an ATA encoding isoleucine (abbreviated I in the one-letter system) to an AAA encoding lysine (abbreviated K). Thus, the designation for the mutation is I1307K. This change is believed to be a neutral variant — that is, it does not alter the function of the APC protein; hence, it may be called both a mutation and a polymorphism.<sup>43</sup> Approximately 6 percent of Ashkenazi Jews and a smaller proportion of other Jews are carriers of the I1307K mutation or polymorphism; it has not been seen in non-Jews.<sup>43-45</sup> As compared with noncarriers, carriers have approximately twice the risk of colorectal cancer.<sup>43</sup> The T-to-A change results in a stretch of eight adenosines (AAAAAAAA) that is believed to increase the risk of somatic mutations as a result of slippage during replication. Examples of these somatic changes in colonic tumors are shown in red above the sequence. For instance, an addition of one A (+A) has been seen in the affected allele of many carriers. The addition or loss of a nucleotide causes a frame shift and loss of function of APC, constituting an important somatic event in tumor initiation.<sup>43,46</sup>

ever, polyps may return while the patient is taking nonsteroidal antiinflammatory drugs. In one study, regression of colonic adenomas occurred in all patients after six months of sulindac (200 mg per day) ( $P < 0.02$ ).<sup>49</sup> However, after a mean of 48.6 months, the number and size of the polyps increased. At a dose of 200 mg, sulindac did not influence the progression of polyps toward a malignant pattern.<sup>49</sup> There is hope that large, ongoing chemoprevention trials will provide concrete clues as to the future of antiinflammatory agents in the prevention of polyps and cancer.<sup>50,51</sup> Currently, none of these chemoprevention strategies should replace screening, although they may delay prophylactic colectomy.<sup>52</sup>

HEREDITARY NONPOLYPOSIS  
COLORECTAL CANCER

**CLINICAL FEATURES**

Hereditary nonpolyposis colorectal cancer, also referred to as the Lynch syndrome, is the most common form of hereditary colorectal cancer. Multiple generations are affected with colorectal cancer at an early age (mean, approximately 45 years) with a predominance of right-sided colorectal cancer (approximately 70 percent proximal to the splenic flexure).

There is an excess of synchronous colorectal cancer (multiple colorectal cancers at or within six months after surgical resection for colorectal cancer) and metachronous colorectal cancer (colorectal cancer occurring more than six months after surgery).<sup>7</sup> In addition, there is an excess of extracolonic cancers — namely, carcinoma of the endometrium (second only to colorectal cancer in frequency), ovary, stomach (particularly in Asian countries such as Japan and Korea<sup>32</sup>), small bowel, pancreas, hepatobiliary tract, brain, and upper uroepithelial tract.<sup>12,53</sup> There is also an apparent statistically significant decrease in the risk of lung cancer,<sup>12</sup> which, while not proved, merits further research. Patients with hereditary nonpolyposis colorectal cancer may also have sebaceous adenomas, sebaceous carcinomas, and multiple keratoacanthomas, findings consonant with Torre's syndrome variant.<sup>7,54</sup>

Figure 4 depicts the evaluation of a family with hereditary nonpolyposis colorectal cancer from initial ascertainment to completion. The figure illustrates the advantage of seeking a more extensive family history when initial information is limited but includes clinical findings suggestive of hereditary nonpolyposis colorectal cancer. For example, two siblings may have colorectal cancer of the prox-

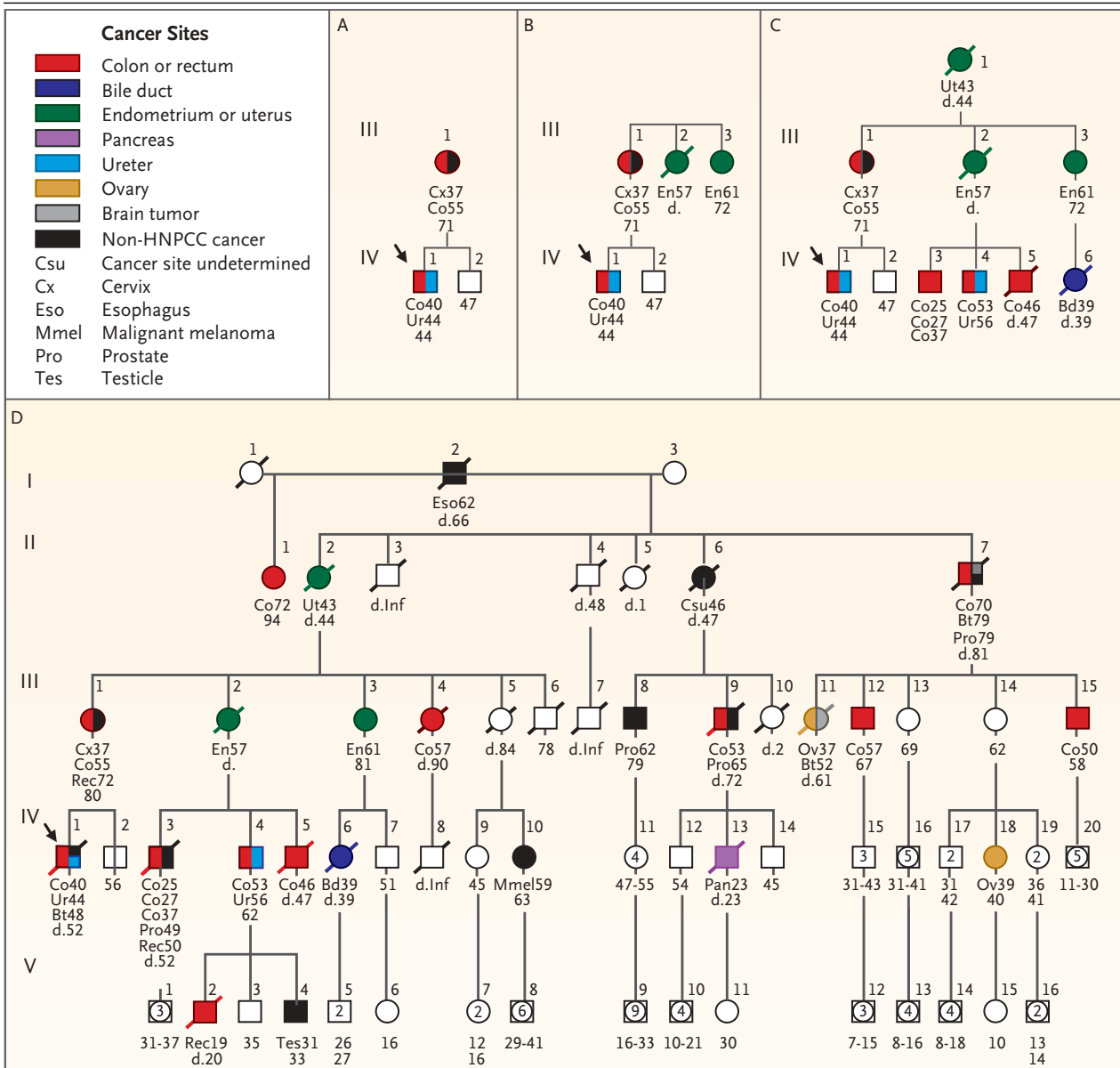

**Figure 4. Initial (Panel A) and Subsequent (Panels B, C, and D) Evaluations of a Pedigree with Classic Hereditary Nonpolyposis Colorectal Cancer.**

Panel A shows the initial assessment of what turned out to be a family with classic hereditary nonpolyposis colorectal cancer (HNPCC). The proband (Subject IV-1; arrow) had early-onset (40 years) colorectal carcinoma and carcinoma of the ureter. These findings by themselves are highly significant clinically. However, his mother (Subject III-1) had uterine cervical carcinoma at the age of 37 years, a tumor not associated with the syndrome, but had colorectal carcinoma at the age of 55 years. In Panel B, further inquiry indicated that the proband's mother (Subject III-1) had two sisters with endometrial carcinoma at the ages of 57 (Subject III-2) and 61 (Subject III-3). This pattern, notwithstanding the Amsterdam criteria, would be sufficient for a diagnosis of hereditary nonpolyposis colorectal cancer. In Panel C, extending the pedigree further showed that one of these maternal aunts (Subject III-2) had three sons with cancer, one with early-onset metachronous colon cancer (Subject IV-3), a second with colon cancer and carcinoma of the ureter (Subject IV-4), and the third with colon cancer alone (Subject IV-5). The other aunt (Subject III-3) had a daughter (Subject IV-6) with cancer of the bile duct. These findings provide strong evidence in support of the diagnosis of hereditary nonpolyposis colorectal cancer. In Panel D, the full pedigree shows findings that continue to support a diagnosis of hereditary nonpolyposis colorectal cancer.<sup>55</sup>

Squares denote male family members; circles female family members; symbols with a slash deceased family members, with the age at death (d) given below each symbol; open symbols unaffected family members; bicolored symbols family members with multiple primary cancers; squares containing numbers the number of unaffected male progeny; circles containing numbers the number of unaffected female progeny; and combined symbols containing numbers the number of unaffected progeny of both sexes. The types of primary cancer and the age (in years) at diagnosis are listed below the symbols, and the bottom-most number is the current age or the age at death. Inf denotes in infancy.

imal colon before the age of 30 years in the absence of multiple colonic adenomas. However, their parents may have died at an early age of causes other than cancer and other relatives with potentially valuable genetic information may simply not be available for testing. Although neither of these clinical scenarios fulfills the Amsterdam I or II criteria for hereditary nonpolyposis colorectal cancer (Table 1), the clinician may prudently wish to err on the side of caution. Additional study of the tumor should include microsatellite-instability testing in at least one of the colorectal cancers or a search for a mutation in a mismatch-repair gene, such as *MSH2* or *MLH1*, in the resected tumor.

**PATHOLOGICAL FEATURES**

As compared with sporadic colorectal cancer, tumors in hereditary nonpolyposis colorectal cancer are more often poorly differentiated, with an excess of mucoid and signet-cell features, a Crohn's-like reaction (lymphoid nodules, including germinal centers, located at the periphery of infiltrating colorectal carcinomas), and the presence of infiltrating lymphocytes within the tumor.<sup>58-61</sup>

**ACCELERATED CARCINOGENESIS**

Accelerated carcinogenesis occurs in hereditary nonpolyposis colorectal cancer. In this setting, a tiny colonic adenoma may emerge as a carcinoma within 2 to 3 years, as opposed to the 8 to 10 years this process may take in the general population.<sup>7,61</sup> This rapid growth leads us to recommend annual colonoscopy, as discussed below.

**FEATURES OF PEDIGREES**

The original definitions based on clinical and pedigree criteria such as the more stringent Amsterdam I criteria<sup>56</sup> or the less stringent Amsterdam II criteria<sup>57</sup> remain valid (Table 1). However, in many situations, even if the criteria are not met, the occurrence of cancers associated with hereditary nonpolyposis colorectal cancer, especially in small families, should alert the clinician to the possibility of hereditary nonpolyposis colorectal cancer, as should cancer at a very early age or multiple cancers in one person (Fig. 5).

**INCIDENCE AND MOLECULAR SCREENING**

When the Amsterdam criteria (Table 1) are used to determine what proportion of all colorectal cancers are due to hereditary nonpolyposis colorectal cancer, estimates range from 1 to 6 percent.<sup>7,22,23,62</sup>

**Table 1. Amsterdam I and Amsterdam II Criteria.\***

**Amsterdam I criteria**

- At least three relatives must have histologically verified colorectal cancer:
  - One must be a first-degree relative of the other two.
  - At least two successive generations must be affected.
  - At least one of the relatives with colorectal cancer must have received the diagnosis before the age of 50 years.
  - Familial adenomatous polyposis must have been excluded.

**Amsterdam II criteria**

- At least three relatives must have a cancer associated with hereditary nonpolyposis colorectal cancer (colorectal, endometrial, stomach, ovary, ureter or renal-pelvis, brain, small-bowel, hepatobiliary tract, or skin [sebaceous tumors]):
  - One must be a first-degree relative of the other two.
  - At least two successive generations must be affected.
  - At least one of the relatives with cancer associated with hereditary nonpolyposis colorectal cancer should have received the diagnosis before the age of 50 years.
  - Familial adenomatous polyposis should have been excluded in any relative with colorectal cancer.
  - Tumors should be verified whenever possible.

\* The Amsterdam I and II criteria are from Vasen et al.<sup>56,57</sup>

Molecular screening of all patients with colorectal cancer for hereditary nonpolyposis colorectal cancer is now both feasible and desirable. Such screening has suggested that upward of 3 percent of all such patients have hereditary nonpolyposis colorectal cancer (Fig. 1). In one study, the mean age at presentation with hereditary nonpolyposis colorectal cancer diagnosed by molecular screening was 54 years old; the study included several patients over 60 years of age, and some had a minimal family history of cancer.<sup>22,23</sup> If further studies confirm these findings, the age at onset may prove older than the mean of 45 years in cases ascertained on the basis of family-history criteria. For this reason, we recommend that whenever population-based screening is performed, it include all patients with colorectal cancer irrespective of age and family history.

Analysis of mutations in mismatch-repair genes has provided estimates of the proportion of such mutations in families with a history consonant with hereditary nonpolyposis colorectal cancer. These estimates range from 40 to 80 percent for families meeting the Amsterdam I criteria and from 5 to 50 percent for families meeting the Amsterdam II criteria.<sup>62,63</sup> Among such families, as well as in other families whose history is consistent with the presence of hereditary nonpolyposis colorectal cancer but who do not meet these formal criteria, some

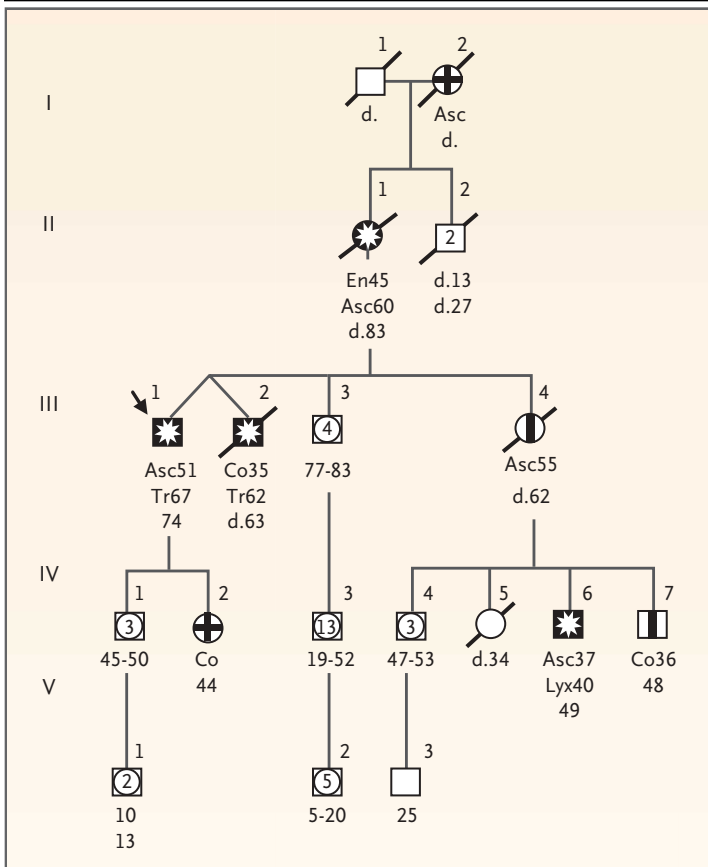

**Figure 5.** Pedigree in Which the Proband (Subject III-1) Had Carcinoma of the Ascending Colon (Asc) at the Age of 51 Years and a Second Primary Carcinoma of the Transverse Colon (Tr) at the Age of 67 Years.

The proband's fraternal twin brother (Subject III-2) had colon cancer (Co) — precise site unknown — at the age of 35 years followed by a second primary cancer of the transverse colon at the age of 62 years. Their sister (Subject III-4) had cancer of the ascending colon at the age of 55 years. Their mother (Subject II-1) had carcinoma of the endometrium (En) at the age of 45 years and carcinoma of the ascending colon at the age of 60 years, and the proband's maternal grandmother had carcinoma of the ascending colon. The proband's daughter had colon cancer at the age of 44 years, and a nephew had carcinoma of the ascending colon at the age of 37 years and carcinoma of the larynx (Lyx) at the age of 40 years. The progeny in the direct genetic lineage of Subjects III-1 and III-4 merit intensive surveillance and would be candidates for genetic testing. The mutation discovered in the family is a missense mutation involving *MLH1*. Squares denote male family members; circles female family members; symbols with a slash deceased family members, with the age at death (d) given below each symbol; open symbols unaffected family members; solid symbols with a star family members with pathological evidence of multiple primary cancers, with the age at diagnosis shown to the right of the types of cancer; a divided symbol a family member with cancer established on the basis of the family history; a symbol with a cross a family member whose cause of death was determined by examining the death certificate or medical records; and combined symbols containing numbers the number of unaffected progeny of both sexes. Bottom-most numbers are current ages.

families will not harbor a known mismatch-repair mutation. This is consistent with the notions that in such families other, as yet undiscovered genes may be responsible for the syndrome and that the aggregation of cancers may be caused by environmental factors or be due to chance.<sup>5</sup>

**GENES AND GERM-LINE MUTATIONS**

Hereditary nonpolyposis colorectal cancer is caused by a germ-line mutation in any of the mismatch-repair genes listed in Table 2. As of this writing, two genes, *MLH1* and *MSH2*, account for almost 90 percent of all identified mutations. *MSH6* accounts for almost 10 percent, but its share of typical as opposed to less typical hereditary nonpolyposis colorectal cancer remains to be determined.<sup>30,31</sup> It is usually sufficient first to screen patients for *MLH1* and *MSH2* and then to test other genes only if mutations are not found in these two.

**ASSESSING THE PATHOGENICITY OF MUTATIONS**

All genomic coding changes are potentially deleterious. However, as opposed to nonsense mutations (which create a stop codon or lead to a frame shift) or those that cause abnormal splicing, missense mutations (which lead to the substitution of an amino acid) are usually not considered a priori pathogenic. Of all mutations identified in *MLH1* and *MSH2*, 29 percent and 16 percent, respectively, are missense mutations. Missense mutations make the interpretation of genotypic data difficult. The mutation data base maintained by the International Collaborative Group on Hereditary Nonpolyposis Colorectal Cancer is an important primary reference (<http://www.nfdht.nl>). Immunohistochemical analysis of mismatch-repair proteins in the tumor can provide clues as to which mismatch-repair gene is involved in tumor pathogenesis if staining for one of the proteins is weak or absent.<sup>25,65</sup>

**SOURCES OF UNDERDIAGNOSIS**

Previous estimates of the frequency of hereditary nonpolyposis colorectal cancer were most likely low. Most analyses of mutations to date have not included analysis of *MSH6*, which undoubtedly causes hereditary nonpolyposis colorectal cancer or a predisposition to an atypical and more benign form of this syndrome.<sup>30</sup> Moreover, conventional mutation analysis overlooks some mutations that can be detected only when the two alleles are studied separately, with the use of more sophisticated techniques.<sup>66</sup> Such techniques permit the detection

of several types of mutation that elude conventional mutation analysis, mainly mutations in control regions or introns that affect transcription or splicing.<sup>67</sup> Finally, large deletions in the MSH2 gene are more common than previously thought and can be detected by Southern hybridization.<sup>68</sup>

**SURVEILLANCE FOR CANCER**

In patients with hereditary nonpolyposis colorectal cancer, annual full colonoscopy, initiated between the ages of 20 and 25 years, is recommended for those with strong clinical evidence or documented germ-line mutations in MLH1, MSH2, or MSH6 (or a combination). Although less frequent colonoscopy (every three years) has been suggested in a consensus statement,<sup>69</sup> we believe this would lead to missed colorectal cancers, given the phenomenon of accelerated carcinogenesis in such cancers.<sup>7,60,61</sup> Extracolonic screening, particularly of the endometrium and ovary, the sites of the second and third most common cancers in this disorder, is indicated in patients with hereditary nonpolyposis colorectal cancer. With respect to the endometrium, annual transvaginal ultrasonography and endometrial aspiration for pathological assessment should be begun at the age of 30 years and repeated annually. In the case of the ovary, this evaluation should include transvaginal ovarian ultrasonography and CA-125 screening, also beginning at the age of 30 years. Patients should be aware of the low sensitivity and specificity of surveillance methods for ovarian cancer. Screening at other sites, such as the upper uroepithelial tract and stomach (particularly in natives of Korea<sup>32</sup> or Japan or in a family with an excess number of cancers at these extracolonic sites) must be considered, but it is difficult.

**EFFICACY OF SURVEILLANCE**

The efficacy of surveillance for colorectal cancer in families with hereditary nonpolyposis colorectal cancer was evaluated in a controlled clinical trial extending over a 15-year period.<sup>70</sup> The study concluded that screening for colorectal cancer at three-year intervals more than halves the risk of colorectal cancer, prevents deaths from colorectal cancer, and decreases the overall mortality rate by about 65 percent in such families. The relatively high incidence of colorectal cancer (albeit nonfatal cases) even among these frequently screened subjects is an argument for shorter screening intervals, such as one year. Prophylactic subtotal colectomy, prophylactic total abdominal hysterectomy, and bilateral sal-

**Table 2. Number of Different Germ-Line Mutations and Polymorphisms Identified in Patients with Hereditary Nonpolyposis Colorectal Cancer.\***

Gene	Total No. of Mutations†	No. of Missense Mutations (% of total)	No. of Polymorphisms‡
MLH1	164	47 (29)	20
MSH2	121	19 (16)	24
MSH6	31	12 (39)	43
PMS1	1	0	0
PMS2	5	1 (20)	5
Total	322	79 (25)	92

\* The mutations are from the data maintained by the International Collaborative Group on Hereditary Non-Polyposis Colorectal Cancer (<http://www.nfdht.nl>). The data base also lists 10 mutations in the MLH3 gene; all but 1 are missense mutations and have so far been reported by a single laboratory.<sup>64</sup> Their putative pathogenetic role remains to be determined.

† The mutations listed are considered disease-causing.

‡ The polymorphisms listed are not considered disease-causing.

pingo-oophorectomy are presented as options to selected patients.<sup>7,71</sup>

The identification of hereditary nonpolyposis colorectal cancer can be lifesaving, since it can lead to the early detection of cancer.<sup>70,72</sup> This effect was quantified in a study by Ramsey et al.,<sup>73</sup> a cost-effectiveness analysis comparing standard care with a process that included the application of the Bethesda guidelines (which identify the colorectal tumors to test for microsatellite instability),<sup>74</sup> followed by testing of the tumor for microsatellite instability, germ-line testing, and lifelong screening for colorectal cancer among carriers of mutations. The cost of screening was \$7,556 per year of life gained when patients with cancer and their siblings and children were considered together.<sup>73</sup>

**SOMATIC MUTATIONS AND THE PROGRESSION TO CANCER**

The multigene, clonal evolution, and selection model of the initiation and progression of cancer proposed by Fearon and Vogelstein originally identified APC, genes on 18q, Ras, and p53 (TP53) as the genes in which mutations or epigenetic dysregulation contributes to the evolution of colon cancer.<sup>75</sup> Although later studies have confirmed this model, many additional genes are also involved.<sup>46,76</sup> What is the role of a mismatch-repair deficiency in this model? In colorectal tumors with a deficiency of mismatch-repair protein, all the named components are involved,<sup>19</sup> but probably to different degrees.<sup>77</sup> It ap-

HAMARTOMATOUS POLYPOSIS SYNDROMES

pears that the genetic pathways are the same even though the involvement of the different genes varies.<sup>78</sup> Figure 6 shows the putative role of mutations in mismatch-repair genes.

**ROLE OF EPIGENETICS**

Methylation of the CpG sites in the promoter region of *MLH1* silences its transcription and, when both alleles are affected, leads to a typical mismatch-repair deficiency.<sup>83,84</sup> This epigenetic change is not heritable and accounts for the majority of all sporadic colorectal cancers that are positive for microsatellite instability.<sup>85-87</sup> These tumors typically affect patients older than 60 years of age and women, are right-sided, and carry the same histologic and prognostic hallmarks as hereditary nonpolyposis colorectal cancers.<sup>15</sup>

The differential diagnosis of juvenile polyposis syndrome includes Cowden’s disease, the Bannayan–Ruvalcaba–Riley syndrome, and the Peutz–Jeghers syndrome, and there are often only very subtle clinical distinctions among them. Hence, the emerging evidence of their molecular bases may allow more precise distinctions to be made among these syndromes (Table 3). For example, germ-line mutations in *PTEN*, a protein tyrosine phosphatase gene, have been identified in Cowden’s disease and Bannayan–Ruvalcaba–Riley syndrome that show that the two syndromes may be allelic and “might even be one and the same syndrome along a broad spectrum.” Eng and Ji discuss the problem of phenotyp-

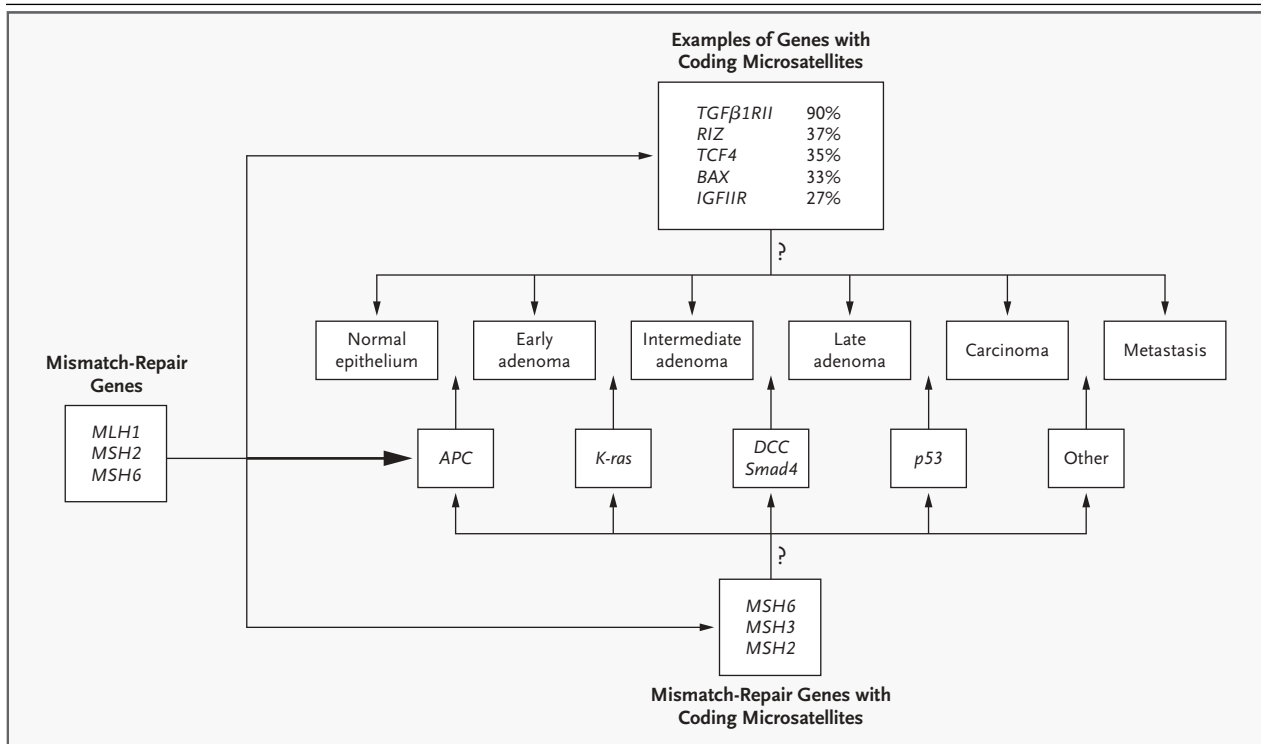

**Figure 6. Putative Role of Mutations in Mismatch-Repair Genes.**

A mutation in one of the three main mismatch-repair genes leads to a deficiency of mismatch-repair proteins, which promotes mutations in some of the traditional genes, such as the adenomatous polyposis coli gene (*APC*) and *K-ras*. Genes with coding microsatellites accumulate frame-shift mutations and lose function, further affecting, and perhaps speeding up, the evolution of cancer. They may also affect the organ specificity of hereditary nonpolyposis colorectal cancers. The approximate percentages of all colorectal-cancer tumors with mismatch-repair deficiency that harbor these frame-shift mutations are shown in the box at the top.<sup>56,76,79,80</sup> Three mismatch-repair genes that have coding microsatellites are shown at the bottom.<sup>81,82</sup> Somatic frame-shift mutations occur in these genes, but their role remains unclear. *TGFB1RII* denotes transforming growth factor  $\beta$  1 receptor II, *RIZ* retinoblastoma-protein–interacting zinc finger, *TCF4* transcription factor 4, *BAX* BCL-2–associated X, *IGF1IR* insulin-like growth factor II receptor, and *DCC* deleted in colorectal cancer.

ic features that may be shared by the various hamartomatous syndromes, thereby contributing to the complexity of clinical diagnosis.<sup>94</sup> They suggest referring such patients to physicians with extensive experience with these disorders.

PROSPECTS FOR PREVENTION AND TREATMENT

Morbidity and mortality from hereditary forms of colorectal cancer should be reduced once a patient's familial or hereditary risk is established and a highly targeted program of cancer surveillance and management is undertaken.<sup>69,70,73</sup> Prevention will be aided by the identification of the causative germ-line mutation in a patient's family, thus confirming the risk. Cancer prevention, particularly among patients with familial adenomatous polyposis and hereditary nonpolyposis colorectal cancer, will be most effective when physicians understand the natural history and the molecular bases of these disorders. They must recognize the need for genetic counseling before DNA testing is performed and at the time the test results are disclosed. A vexing problem is the perception of many high-risk patients that participating in genetic-testing, clinical, and research programs, which can contribute to the identification and ultimate prevention and reduction in morbidity and mortality from hereditary cancer syndromes, will result in discrimination by insurance companies or employers.<sup>9,95-97</sup> Legislative bodies need to enact laws that will protect such patients from potential discrimination.<sup>95-98</sup>

In addition to diagnostic methods, physicians must also be familiar with the available screening methods and with the options for surgical prophylaxis, particularly prophylactic colectomy in patients with familial adenomatous polyposis and prophylactic colectomy and prophylactic bilateral salpingo-oophorectomy (the latter when childbearing is complete) in patients with hereditary nonpolyposis colorectal cancer. Technologic advances in both cancer screening and the identification of biologic markers of cancer susceptibility, such as microsatellite instability, and ultimately specific germ-line testing, will expedite attempts to achieve these can-

**Table 3. Hamartomatous Polyposis Syndromes.**

Syndrome	Phenotype	Mutant Gene*
Peutz-Jeghers syndrome	Perioral pigmentations, pigmentations of fingers, upper and lower gastrointestinal hamartomatous lesions, small-bowel and pancreatic cancer, colorectal cancer and sex-cord tumors with annular tubules of the ovary	<i>LKB1 (STK11)</i> <sup>88</sup>
Familial juvenile polyposis	Gastrointestinal hamartomatous polyps, increased risk of gastrointestinal cancer (stomach, colorectum)†	<i>Smad4 (DPC4)</i> <sup>89</sup> <i>BMPRIA</i> <sup>90</sup> <i>PTEN</i> <sup>91</sup>
Cowden's disease‡	Colonic hamartomatous polyps, benign and malignant neoplasms of the thyroid, breast, uterus, and skin (multiple trichilemmomas)§	<i>PTEN (MMAC1, DEP1)</i> <sup>92,93</sup>
Bannayan-Ruvalcaba-Riley syndrome	Microcephaly, fibromatosis, hamartomatous polyposis, hemangiomas, speckled penis§	<i>PTEN</i>

\* Alternative names are given in parentheses.

† The diagnosis is made only when features pathognomonic of the other syndromes are not present.

‡ Finding a germ-line mutation in *PTEN* provides molecular evidence of Cowden's disease, but the absence of an identifiable *PTEN* mutation is non-diagnostic.

§ A firm association with colorectal cancer has yet to be identified.

cer-prevention goals. Pharmacologic treatment that is based on molecular-targeting strategies holds great promise.<sup>99,100</sup>

Finally, molecular genetic research on hereditary forms of colorectal cancer must continue to search for new mutations in these heterogeneous disorders. For example, researchers have described germ-line mutations in *MYH* in classic familial adenomatous polyposis coli showing apparent autosomal recessive inheritance.<sup>101,102</sup>

Supported by revenue from Nebraska cigarette taxes awarded to Creighton University by the Nebraska Department of Health and Human Services and by grants (1U01 CA86389-01, P30 CA16058, and R01 CA67941) from the National Institutes of Health and by Folkhälsan Institute of Genetics, Helsinki, Finland.

The contents of this article are solely the responsibility of the authors and do not necessarily represent the official views of the State of Nebraska or the Nebraska Department of Health and Human Services.

We are indebted to Trudy Shaw, M.A., for her faithful and diligent technical assistance throughout the development of this manuscript, and to Jane Lynch, B.S.N., who was a constant source of help in our family studies and in portions of the writing of this article.

REFERENCES

1. Jemal A, Thomas A, Murray T, Thun M. Cancer statistics, 2002. *CA Cancer J Clin* 2002;52:23-47. [Errata, *CA Cancer J Clin* 2002;52:119, 181-2.]
2. Polednak AP. Do physicians discuss genetic testing with family-history-positive breast cancer patients? *Conn Med* 1998;62:3-7.
3. Cho MK, Sankar P, Wolpe PR, Godmilow L. Commercialization of BRCA1/2 testing: practitioner awareness and use of a new genetic test. *Am J Med Genet* 1999;83:157-63.
4. Giardiello FM, Brensinger JD, Petersen GM, et al. The use and interpretation of com-

- mercial APC gene testing for familial adenomatous polyposis. *N Engl J Med* 1997; 336:823-7.
5. Vogelstein B, Kinzler KW, eds. The genetic basis of human cancer. New York: McGraw-Hill, 1998.
6. Eng C, Hampel H, de la Chapelle A. Genetic testing for cancer predisposition. *Annu Rev Med* 2001;52:371-400. [Erratum, *Annu Rev Med* 2002;53:xi.]
7. Lynch HT, de la Chapelle A. Genetic susceptibility to non-polyposis colorectal cancer. *J Med Genet* 1999;36:801-18.
8. Lynch HT. Family information service and hereditary cancer. *Cancer* 2001;91:625-8.
9. Aktan-Collan K, Mecklin JP, Jarvinen HJ, et al. Predictive genetic testing for hereditary non-polyposis colorectal cancer: uptake and long-term satisfaction. *Int J Cancer* 2000; 89:44-50.
10. Lynch HT, Smyrk T, McGinn T, et al. Attenuated familial adenomatous polyposis (AFAP): a phenotypically and genotypically distinctive variant of FAP. *Cancer* 1995;76: 2427-33.
11. Lynch HT, Lynch JF, Casey MJ, Bewtra C, Narod SA. Genetics of gynecological cancer. In: Hoskins WJ, Perez CA, Young RC, eds. Principles and practice of gynecologic oncology. 3rd ed. Philadelphia: Lippincott Williams & Wilkins, 2000:29-53.
12. Watson P, Lynch HT. The tumor spectrum in HNPCC. *Anticancer Res* 1994;14: 1635-9.
13. Watson P, Lin KM, Rodriguez-Bigas MA, et al. Colorectal carcinoma survival among hereditary nonpolyposis colorectal carcinoma family members. *Cancer* 1998;83:259-66.
14. Sankila R, Aaltonen LA, Jarvinen HJ, Mecklin J-P. Better survival rates in patients with MLH1-associated hereditary colorectal cancer. *Gastroenterology* 1996;110:682-7.
15. Gryfe R, Kim H, Hsieh ET, et al. Tumor microsatellite instability and clinical outcome in young patients with colorectal cancer. *N Engl J Med* 2000;342:69-77.
16. Branch P, Bicknell DC, Rowan A, Bodmer WF, Karran P. Immune surveillance in colorectal carcinoma. *Nat Genet* 1995;9: 231-2.
17. Shashidharan M, Smyrk T, Lin KM, et al. Histologic comparison of hereditary non-polyposis colorectal cancer associated with MSH2 and MLH1 and colorectal cancer from the general population. *Dis Colon Rectum* 1999;42:722-6.
18. Boman BM, Fry RD, Curran W, et al. Unique immunohistochemical features of MSI-classified tumors from HNPCC patients. *Prog Proc Am Soc Clin Oncol* 1999;18:236a. abstract.
19. Aaltonen LA, Peltomaki P, Leach FS, et al. Clues to the pathogenesis of familial colorectal cancer. *Science* 1993;260:812-6.
20. Peltomaki P, Lothe RA, Aaltonen LA, et al. Microsatellite instability is associated with tumors that characterize the hereditary non-polyposis colorectal carcinoma syndrome. *Cancer Res* 1993;53:5853-5.
21. Boland CR, Thibodeau SN, Hamilton SR, et al. A National Cancer Institute workshop on microsatellite instability for cancer detection and familial predisposition: development of international criteria for the determination of microsatellite instability in colorectal cancer. *Cancer Res* 1998;58:5248-57.
22. Aaltonen LA, Salovaara R, Kristo P, et al. Incidence of hereditary nonpolyposis colorectal cancer and the feasibility of molecular screening for the disease. *N Engl J Med* 1998;338:1481-7.
23. Salovaara R, Loukola A, Kristo P, et al. Population-based molecular detection of hereditary nonpolyposis colorectal cancer. *J Clin Oncol* 2000;18:2193-200. [Erratum, *J Clin Oncol* 2000;18:3456.]
24. Lothe RA, Peltomaki P, Meling GI, et al. Genomic instability in colorectal cancer: relationship to clinicopathological variables and family history. *Cancer Res* 1993;53: 5849-52.
25. Thibodeau SN, French AJ, Cunningham JM, et al. Microsatellite instability in colorectal cancer: different mutator phenotypes and the principal involvement of hMLH1. *Cancer Res* 1998;58:1713-8.
26. Zhou X-P, Hoang J-M, Li Y-J, et al. Determination of the replication error phenotype in human tumors without the requirement for matching normal DNA by analysis of mononucleotide repeat microsatellites. *Genes Chromosomes Cancer* 1998;21:101-7.
27. de la Chapelle A. Testing tumors for microsatellite instability. *Eur J Hum Genet* 1999;7:407-8.
28. Nyström-Lahti M, Kristo P, Nicolaidis NC, et al. Founding mutations and Alu-mediated recombination in hereditary colon cancer. *Nat Med* 1995;1:1203-6.
29. Aaltonen LA, Peltomaki P, Mecklin JP, et al. Replication errors in benign and malignant tumors from hereditary nonpolyposis colorectal cancer patients. *Cancer Res* 1994; 54:1645-8.
30. Miyaki M, Konishi M, Tanaka K, et al. Germline mutation of MSH6 as the cause of hereditary nonpolyposis colorectal cancer. *Nat Genet* 1997;17:271-2.
31. Wijnen J, de Leeuw W, Vasen H, et al. Familial endometrial cancer in female carriers of MSH6 germline mutations. *Nat Genet* 1999;23:142-4.
32. Park YJ, Shin K-H, Park J-G. Risk of gastric cancer in hereditary nonpolyposis colorectal cancer in Korea. *Clin Cancer Res* 2000;6:2994-8.
33. Burke C. Risk stratification for perianapillary carcinoma in patients with familial adenomatous polyposis: does Theodore know what to do now? *Gastroenterology* 2001;121:1246-8.
34. Björk J, Akerbrant H, Iselius L, et al. Periapillary adenomas and adenocarcinomas in familial adenomatous polyposis: cumulative risks and APC gene mutations. *Gastroenterology* 2001;121:1127-35.
35. Lynch HT, Fitzgibbons R Jr, Chong S, et al. Use of doxorubicin and dacarbazine for the management of unresectable intra-abdominal desmoid tumors in Gardner's syndrome. *Dis Colon Rectum* 1994;37:260-7.
36. Lynch HT, Fitzgibbons R Jr. Surgery, desmoid tumors, and familial adenomatous polyposis: case report and literature review. *Am J Gastroenterol* 1996;91:2598-601.
37. Lynch HT, Lynch PM. Negative genetic test result in familial adenomatous polyposis. *Dis Colon Rectum* 1999;42:310-2.
38. Lynch HT, Smyrk TC. Classification of familial adenomatous polyposis: a diagnostic nightmare. *Am J Hum Genet* 1998;62: 1288-9.
39. Lynch HT, Tinley ST, Lynch J, Vanderhoof J, Lemon SJ. Familial adenomatous polyposis: discovery of a family and its management in a cancer genetics clinic. *Cancer* 1997;80:Suppl:614-20.
40. Lynch HT, Smyrk T, Lynch J, Lanspa S, McGinn T, Cavalieri RJ. Genetic counseling in an extended attenuated familial adenomatous polyposis kindred. *Am J Gastroenterol* 1996;91:455-9.
41. Lynch HT. Desmoid tumors: genotype-phenotype differences in familial adenomatous polyposis — a nosological dilemma. *Am J Hum Genet* 1996;59:1184-5.
42. Brensinger JD, Laken SJ, Luce MC, et al. Variable phenotype of familial adenomatous polyposis in pedigrees with 3' mutation in the APC gene. *Gut* 1998;43:548-52.
43. Laken SJ, Petersen GM, Gruber SB, et al. Familial colorectal cancer in Ashkenazim due to a hypermutable tract in APC. *Nat Genet* 1997;17:79-83.
44. Prior TW, Chadwick RB, Papp AC, et al. The I1307K polymorphism of the APC gene in colorectal cancer. *Gastroenterology* 1999; 116:58-63.
45. Rozen P, Shomrat R, Strul H, et al. Prevalence of the I1307K APC gene variant in Israeli Jews of differing ethnic origin and risk for colorectal cancer. *Gastroenterology* 1999; 116:54-7.
46. Kinzler KW, Vogelstein B. Lessons from hereditary colon cancer. *Cell* 1996;87:159-70.
47. Herrera L, ed. Familial adenomatous polyposis. New York: Alan R. Liss, 1990.
48. Steinbach G, Lynch PM, Phillips RKS, et al. The effect of celecoxib, a cyclooxygenase-2 inhibitor, in familial adenomatous polyposis. *N Engl J Med* 2000;342:1946-52.
49. Tonelli F, Valanzano R, Messerini L, Ficari F. Long-term treatment with sulindac in familial adenomatous polyposis: is there an actual efficacy in prevention of rectal cancer? *J Surg Oncol* 2000;74:15-20.
50. Burn J, Chapman PD, Mathers J, et al. The protocol for a European double-blind trial of aspirin and resistant starch in familial adenomatous polyposis: the CAPP study. *Eur J Cancer* 1995;31A:1385-6.
51. Williamson SLH, Kartheuser A, Coaker J, et al. Intestinal tumorigenesis in the *Apcl638N* mouse treated with aspirin and

- resistant starch for up to 5 months. *Carcinogenesis* 1999;20:805-10.
52. Lynch HT, Thorson AG, Smyrk T. Rectal cancer after prolonged sulindac chemoprevention: a case report. *Cancer* 1995;75:936-8.
53. Aarnio M, Sankila R, Pukkala E, et al. Cancer risk in mutation carriers of DNA-mismatch-repair genes. *Int J Cancer* 1999;81:214-8.
54. Fusaro RM, Lemon SJ, Lynch HT. The Muir-Torre syndrome: a variant of the hereditary nonpolyposis colorectal cancer syndrome. *J Tumor Marker Oncol* 1996;11:19-31.
55. Lynch HT, Richardson JD, Amin M, et al. Variable gastrointestinal and urologic cancers in a Lynch syndrome II kindred. *Dis Colon Rectum* 1991;34:891-5.
56. Vasen HFA, Mecklin J-P, Khan PM, Lynch HT. The International Collaborative Group on Hereditary Nonpolyposis Colorectal Cancer (ICG-HNPCC). *Dis Colon Rectum* 1991;34:424-5.
57. Vasen HFA, Watson P, Mecklin J-P, Lynch HT. New clinical criteria for hereditary nonpolyposis colorectal cancer (HNPCC, Lynch syndrome) proposed by the International Collaborative Group on HNPCC. *Gastroenterology* 1999;116:1453-6.
58. Smyrk TC, Watson P, Kaul K, Lynch HT. Tumor-infiltrating lymphocytes are a marker for microsatellite instability in colorectal carcinoma. *Cancer* 2001;91:2417-22.
59. Alexander J, Watanabe T, Wu T-T, Rashid A, Li S, Hamilton SR. Histopathological identification of colon cancer with microsatellite instability. *Am J Pathol* 2001;158:527-35.
60. Jass JR, Do K-A, Simms LA, et al. Morphology of sporadic colorectal cancer with DNA replication errors. *Gut* 1998;42:673-9.
61. Jass JR, Stewart SM. Evolution of hereditary non-polyposis colorectal cancer. *Gut* 1992;33:783-6.
62. Lynch J. The genetics and natural history of hereditary colon cancer. *Semin Oncol Nurs* 1997;13:91-8.
63. Nyström-Lahti M, Wu Y, Moisio A-L, et al. DNA mismatch repair gene mutations in 55 kindreds with verified or putative hereditary non-polyposis colorectal cancer. *Hum Mol Genet* 1996;5:763-9.
64. Wu Y, Berends MJW, Sijmons RH, et al. A role for MLH3 in hereditary nonpolyposis colorectal cancer. *Nat Genet* 2001;29:137-8.
65. Lindor NM, Burgart LJ, Leontovich O, et al. Immunohistochemistry versus microsatellite instability testing in phenotyping colorectal tumors. *J Clin Oncol* 2002;20:1043-8.
66. Yan H, Papadopoulos N, Marra G, et al. Conversion of diploidy to haploidy. *Nature* 2000;403:723-4.
67. Nakagawa H, Yan H, Lockman J, et al. Allele separation facilitates interpretation of potential splicing alterations and genomic rearrangements. *Cancer Res* 2002;62:4579-82.
68. Wijnen J, van der Klift H, Vasen H, et al. MSH2 genomic deletions are a frequent cause of HNPCC. *Nat Genet* 1998;20:326-8.
69. Burke W, Petersen G, Lynch P, et al. Recommendations for follow-up care of individuals with an inherited predisposition to cancer. I. Hereditary nonpolyposis colon cancer. *JAMA* 1997;277:915-9.
70. Järvinen HJ, Aarnio M, Mustonen H, et al. Controlled 15-year trial on screening for colorectal cancer in families with hereditary nonpolyposis colorectal cancer. *Gastroenterology* 2000;118:829-34.
71. Lynch HT. Is there a role for prophylactic subtotal colectomy among hereditary nonpolyposis colorectal cancer germline mutation carriers? *Dis Colon Rectum* 1996;39:109-10.
72. Houlston RS, Collins A, Slack J, Morton NE. Dominant genes for colorectal cancer are not rare. *Ann Hum Genet* 1992;56:99-103.
73. Ramsey SD, Clarke L, Etzioni R, Higashi M, Berry K, Urban N. Cost-effectiveness of microsatellite instability screening as a method for detecting hereditary nonpolyposis colorectal cancer. *Ann Intern Med* 2001;135:577-88.
74. Rodriguez-Bigas MA, Boland CR, Hamilton SR, et al. A National Cancer Institute workshop on hereditary nonpolyposis colorectal cancer syndrome: meeting highlights and Bethesda guidelines. *J Natl Cancer Inst* 1997;89:1758-62.
75. Fearon ER, Vogelstein B. A genetic model for colorectal tumorigenesis. *Cell* 1990;61:759-67.
76. Ilyas M, Straub J, Tomlinson IPM, Bodmer WF. Genetic pathways in colorectal and other cancers. *Eur J Cancer* 1999;35:335-51.
77. Konishi M, Kikuchi-Yanoshita R, Tanaka K, et al. Molecular nature of colon tumors in hereditary nonpolyposis colorectal cancer, familial polyposis, and sporadic colon cancer. *Gastroenterology* 1996;111:307-17.
78. Huang J, Papadopoulos N, McKinley AJ, et al. APC mutations in colorectal tumors with mismatch repair deficiency. *Proc Natl Acad Sci U S A* 1996;93:9049-54.
79. Duval A, Rolland S, Compoint A, et al. Evolution of instability at coding and non-coding repeat sequences in human MSI-H colorectal cancers. *Hum Mol Genet* 2001;10:513-8.
80. Chadwick RB, Jiang G-L, Bennington GA, et al. Candidate tumor suppressor RIZ is frequently involved in colorectal carcinogenesis. *Proc Natl Acad Sci U S A* 2000;97:2662-7.
81. Chadwick RB, Pyatt RE, Niemann TH, et al. Hereditary and somatic DNA mismatch repair gene mutations in sporadic endometrial carcinoma. *J Med Genet* 2001;38:461-6.
82. Malkhosyan S, Rampino N, Yamamoto H, Perucho M. Frameshift mutator mutations. *Nature* 1996;382:499-500.
83. Kane MF, Loda M, Gaida GM, et al. Methylation of the hMLH1 promoter correlates with lack of expression of hMLH1 in sporadic colon tumors and mismatch repair-defective human tumor cell lines. *Cancer Res* 1997;57:808-11.
84. Herman JG, Umar A, Polyak K, et al. Incidence and functional consequences of hMLH1 promoter hypermethylation in colorectal carcinoma. *Proc Natl Acad Sci U S A* 1998;95:6870-5.
85. Cunningham JM, Christensen ER, Tester DJ, et al. Hypermethylation of the hMLH1 promoter in colon cancer with microsatellite instability. *Cancer Res* 1998;58:3455-60.
86. Veigl ML, Kasturi L, Olechnowicz J, et al. Biallelic inactivation of hMLH1 by epigenetic gene silencing, a novel mechanism causing human MSI cancers. *Proc Natl Acad Sci U S A* 1998;95:8698-702.
87. Nakagawa H, Chadwick RB, Peltomäki P, Plass C, Nakamura Y, de la Chapelle A. Loss of imprinting of the insulin-like growth factor II gene occurs by biallelic methylation in a core region of H19-associated CTCF-binding sites in colorectal cancer. *Proc Natl Acad Sci U S A* 2001;98:591-6.
88. Hemminki A, Markie D, Tomlinson I, et al. A serine/threonine kinase gene defective in Peutz-Jeghers syndrome. *Nature* 1998;391:184-7.
89. Howe JR, Roth S, Ringold JC, et al. Mutations in the SMAD4/DPC4 gene in juvenile polyposis. *Science* 1998;280:1086-8.
90. Howe JR, Bair JL, Sayed MG, et al. Germline mutations of the gene encoding bone morphogenetic protein receptor 1A in juvenile polyposis. *Nat Genet* 2001;28:184-7.
91. Lynch ED, Ostermeyer EA, Lee MK, et al. Inherited mutations in PTEN that are associated with breast cancer, Cowden disease, and juvenile polyposis. *Am J Hum Genet* 1997;61:1254-60.
92. Liaw D, Marsh DJ, Li J, et al. Germline mutations of the PTEN gene in Cowden disease, an inherited breast and thyroid cancer syndrome. *Nat Genet* 1997;16:64-7.
93. Marsh DJ, Coulon V, Lunetta KL, et al. Mutation spectrum and genotype-phenotype analyses in Cowden disease and Bannayan-Zonana syndrome, two hamartoma syndromes with germline PTEN mutation. *Hum Mol Genet* 1998;7:507-15.
94. Eng C, Ji H. Molecular classification of the inherited hamartoma polyposis syndromes: clearing the muddied waters. *Am J Hum Genet* 1998;62:1020-2.
95. Matloff ET, Shappell H, Brierley K, Bernhardt BA, McKinnon W, Peshkin BN. What would you do? Specialists' perspectives on cancer genetic testing, prophylactic surgery, and insurance discrimination. *J Clin Oncol* 2000;18:2484-92.
96. Pokorski RJ, Sanderson P, Bennett N, et al. Insurance issues and genetic testing: challenges and recommendations: workshop no. 1. *Cancer* 1997;80:Suppl:627.
97. The Ad Hoc Committee on Genetic Testing/Insurance Issues. Genetic testing and insurance. *Am J Hum Genet* 1995;56:327-31.
98. Balanced Budget Act of 1997, Pub. L. No. 105-33, 105th Cong. 1st Sess.
99. Druker BJ, Talpaz M, Resta DJ, et al. Efficacy and safety of a specific inhibitor of

- the BCR-ABL tyrosine kinase in chronic myeloid leukemia. *N Engl J Med* 2001;344:1031-7.
- 100.** Druker BJ, Sawyers CL, Kantarjian H, et al. Activity of a specific inhibitor of the BCR-ABL tyrosine kinase in the blast crisis of chronic myeloid leukemia and acute lymphoblastic leukemia with the Philadelphia chromosome. *N Engl J Med* 2001;344:1038-42. [Erratum, *N Engl J Med* 2001;345:232.]
- 101.** Al-Tassan N, Chmiel NH, Maynard J, et al. Inherited variants of MYH associated with somatic G:C→T:A mutations in colorectal tumors. *Nat Genet* 2002;30:227-32.
- 102.** Sieber OM, Lipton L, Crabtree M, et al. Multiple colorectal adenomas, classic adenomatous polyposis, and germ-line mutations in MYH. *N Engl J Med* 2003;348:791-9.

*Copyright © 2003 Massachusetts Medical Society.*

**APPLY FOR JOBS ELECTRONICALLY AT THE NEW NEJM CAREER CENTER**

Physicians registered at the new NEJM Career Center can now apply for jobs electronically using their own cover letters and CVs. You can now keep track of your job-application history with a personal account that is created when you register with the Career Center and apply for jobs seen online at our Web site. Visit [www.nejmjobs.org](http://www.nejmjobs.org) for more information.